

# P.I.D.I

Particle Inspector via Darkfield Illumination



# ASML



Kirolos Kellini

Photonics Engineering Major



Julian Lopez

Photonics Engineering Major

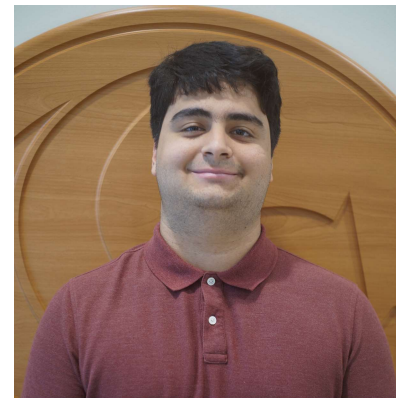

Christian Carroz

Computer Engineering Major



Ryan Palumbo

Mechanical Engineering Major

# Motivation and Background

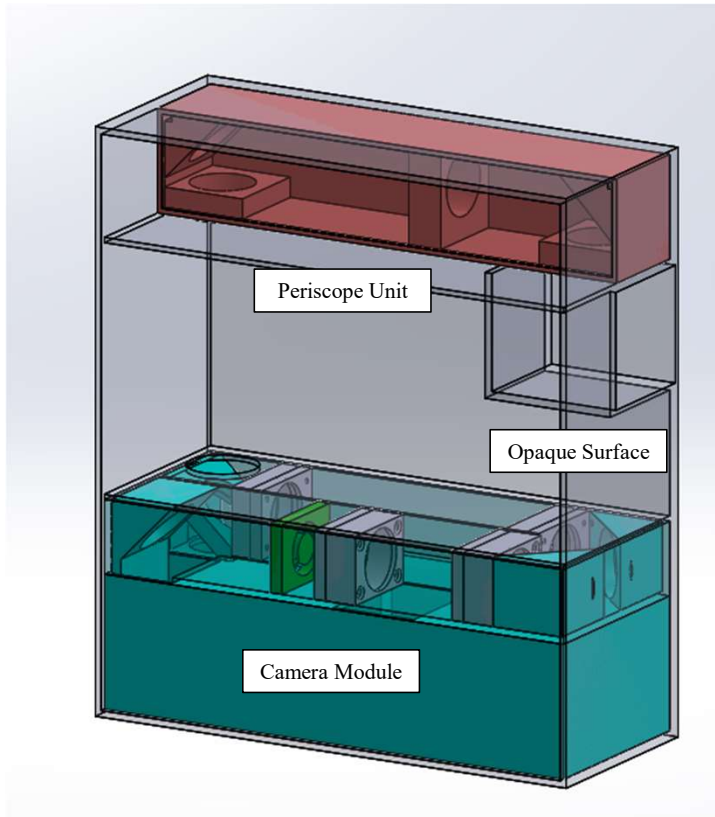

Why did we build this device?

- To **detect small contaminants** on a surface using darkfield illumination
- Use darkfield type illumination to increase detection around edges and enable clearer **imaging of clear particles**
- Enable industries, like semiconductor manufacturing, that require **high precision** and low tolerances for the presence of contaminants.

\*We cannot share system design calculations and dimensions due to a non-disclosure agreement with ASML\*



# Darkfield vs Brightfield

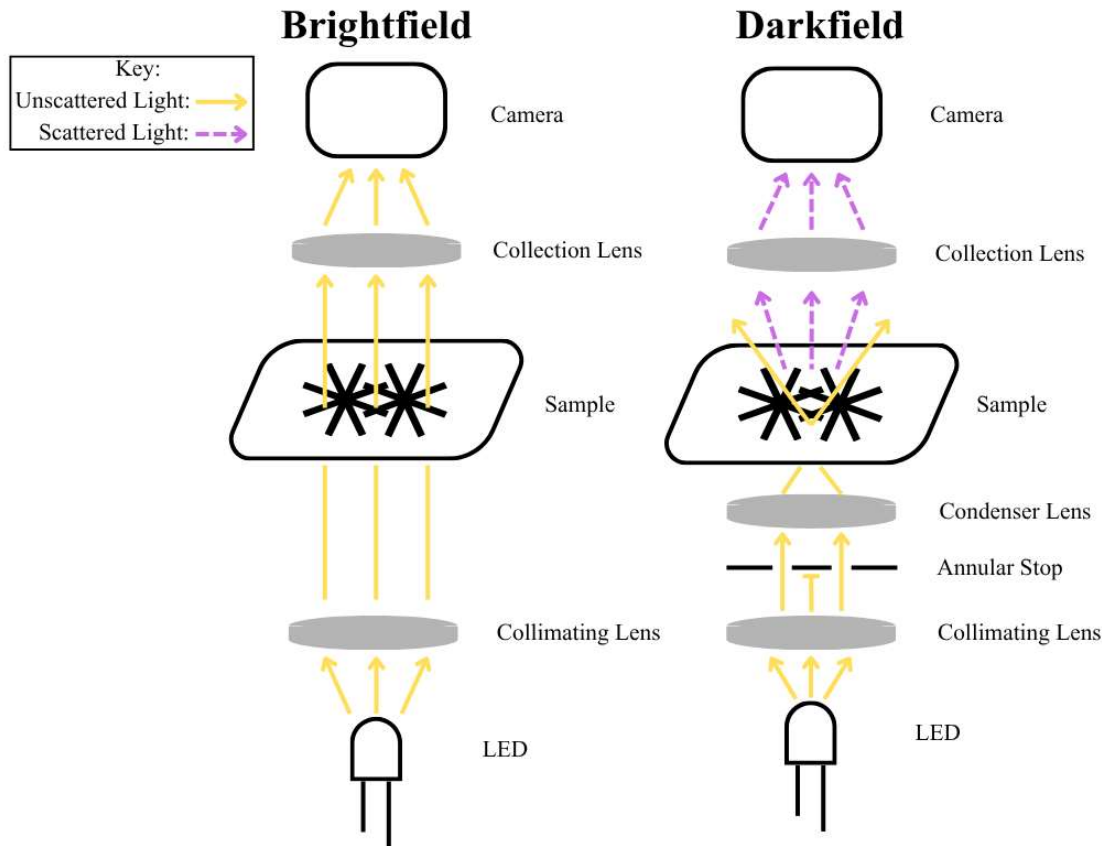

- Brightfield microscopy:
  - Uses direct illumination and works well on samples that are thick or have high absorption
  - Produces low contrast for small or transparent samples
- Darkfield microscopy:
  - Blocks direct light and only captures scattered light
  - Improves contrast, making small, low-absorption particles (like dust) easier to see.

\*We cannot share system design calculations and dimensions due to a non-disclosure agreement with ASML\*



# Basic Goals and Objectives

- Goal:
  - Build and design an **optical module** that fits the sponsor size constraints to inspect contamination **particles of 200  $\mu\text{m}$**  on an opaque surface using **darkfield illumination**
    - Objectives:
      - Design a magnification system capable of viewing particles of 200  $\mu\text{m}$  and determine the respective **focal length of the lenses required**
      - Design darkfield illumination system with **enough scatter** to ensure **clear particles are visible**

# Basic Goals and Objectives (Continued)



- Goal:
  - **Image the opaque surface** and determine if the opaque surface contains contaminants.
    - Objectives:
      - Determine the appropriate **LED and camera** for illumination and detection.
      - Develop an **algorithm to identify** the presence of contaminants in **less than 2 second**
- Goal:
  - Ensure the optical module is **simple to use** and can be operated by anyone
    - Objective:
      - Design a case to house and align all components ensuring that **minimal optical alignment is required for the user**

# Advanced Goals and Objectives



## Goal:

- **Control the system** using a small **touch screen** and display the image and **results with an LCD screen**

## Objectives:

- Implement an **on-device UI** that fits the size constraints
- Implement a system that allows us to **quickly log** whether our algorithm reported a **false positive**

## Goal:

- Stabilize LED and electronics **temperatures** during extended operation

## Objective:

- Integrate **passive thermal management** to limit internal temperature rise over **continuous LED & camera use**

# Stretch Goals and Objectives



## Goal:

- Accurately record the particle spectrum to **identify types of contaminants** found on surface
  - Objective:
    - Design an algorithm that will automatically **store the optical spectrums into a library** and **log the types of contaminants** found on objective

## Goal:

- Enable precise, repeatable fine-focus adjustments
  - Objectives:
    - **Add a manual focus knob** that shifts the sample stage in 1  $\mu\text{m}$  increments
    - Design an algorithm to **automatically adjust the brightness of LED** and use **image processing techniques** to detect hard to observe contaminants

# Stretch Goals and Objectives (Continued)



- Goal:
  - Switch between **bright-field** and **darkfield** illumination.
  - Objective:
    - Design removable annular stop and software to compensate the switch of illumination modes

# Engineering Specifications

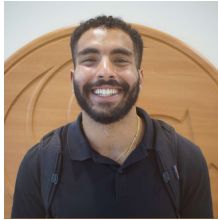

Parameter	Description	Target Value and Unit(s)
Image Processing Time	Amount of time image processing takes to compute difference between tests	< 2 seconds
Imaging Capability	Object magnification to detect 200 $\mu\text{m}$ fibers with the width of 50 $\mu\text{m}$	- 0.25 demagnification - Detect 200 $\mu\text{m}$ x 50 $\mu\text{m}$ particles
Particle Detection False Positive Rate	False positive rate indicates the rate at which a surface is falsely deemed to be noncontaminated by the algorithm	< 0.1%
Image Capture Response Time	Time it takes to capture image	<1 second
Dimensions	Meet dimensions and spacing requirements for camera module, periscope unit and opaque surface	- Camera module: 80 mm $\times$ 80 mm $\times$ 200 mm - Periscope unit: 40 mm $\times$ 40 mm $\times$ 200 mm - Distance between camera module and periscope unit: 100 mm - Distance between periscope unit and opaque surface: 40mm
Weight	It should be easy to move around and transport.	$\leq$ 10 kg
Cost	Provided by ASML	\$5,000

# House of Quality

- 6 customer priorities mapped against 9 engineering parameters to drive design decisions
- Size vs. performance is the key design tension, flagged by negative correlations in the roof
- 0.25× demagnification is the critical optical specification driving downstream project trade-offs

Correlations	
Positive	+
Negative	-
No Correlation	○

Relationships	
Strongly Positive	↑↑
Positive	↑
No Relation	○
Negative	↓
Strongly Negative	↓↓

  

Direction of Improvement	
Maximize	▲
Target	◇
Minimize	▼



Column #		1	2	3	4	5	6	7	8	9
Customer Requirements	Engineering Requirements	Periscope Unit Size	Camera Unit Size	Demagnification	Image Processing Time	False Positive Rate	Battery Life	Cost	Weight	Image Capture Response Time
	Direction of Desirability	◇	◇	▲	▼	▼	▲	▼	▼	▼
Affordability	▲	↓	↓	↓↓	○	○	↓	↑↑	↓	○
Durability	▲	↓	↓	○	○	○	↑	↓	↓↓	○
Image Quality	▲	○	○	↓	↓	↑	○	↓	○	↓
Portability	▼	↑↑	↑↑	↓	○	○	↓	○	↑↑	○
Reliability	▲	○	○	○	↑↑	↑↑	↑	↓	↑	↑
Ease of Use	▲	○	○	○	↑	↑	↑↑	↓	↑	↑↑
Target		40x40x200mm	80x80x200mm	0.25 X	≤ 2s	<0.1%	Up to 1 hour	≤ \$5,000	<10 kg	< 1s

# Overall Block Diagram

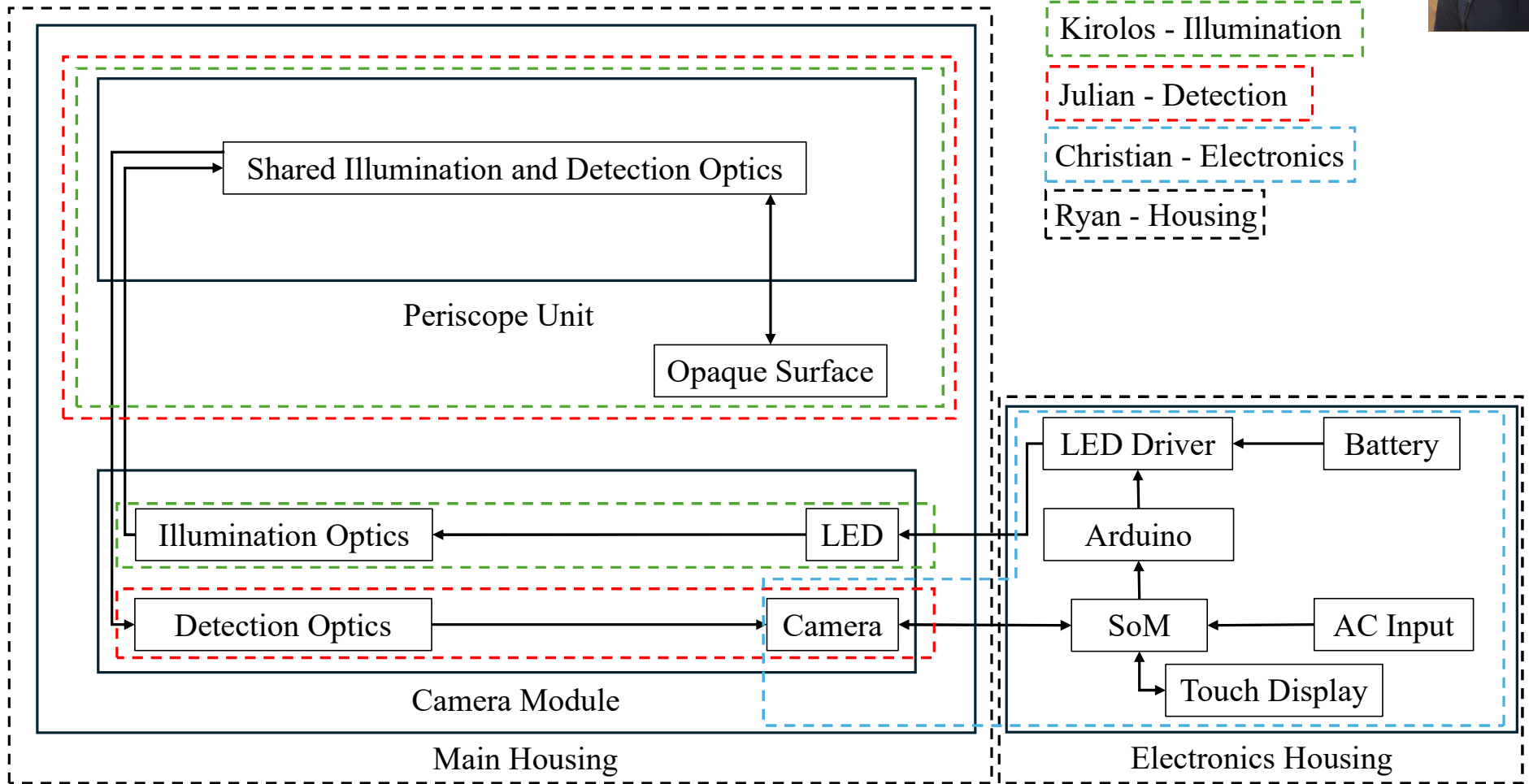

# Full System Prototype

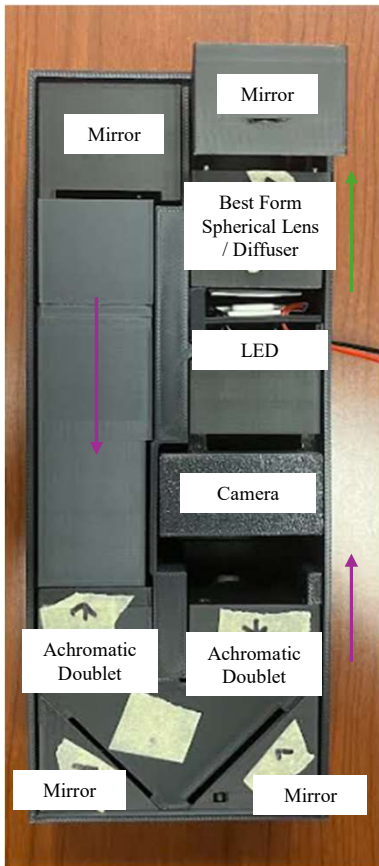

Camera Module Bottom Level (Bottom)



Camera Module Bottom Level (Top)

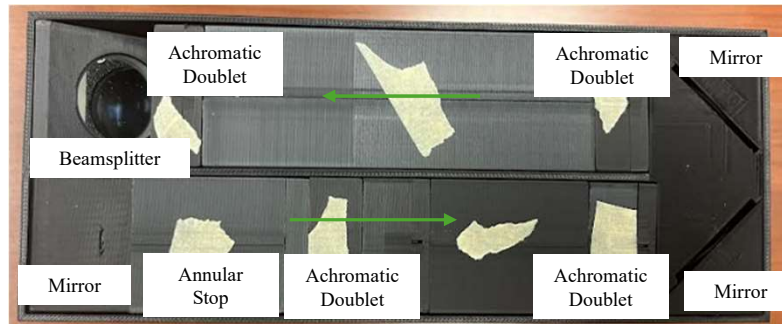

Camera Module Top Level

— Illumination Light  
 ← Detection Light

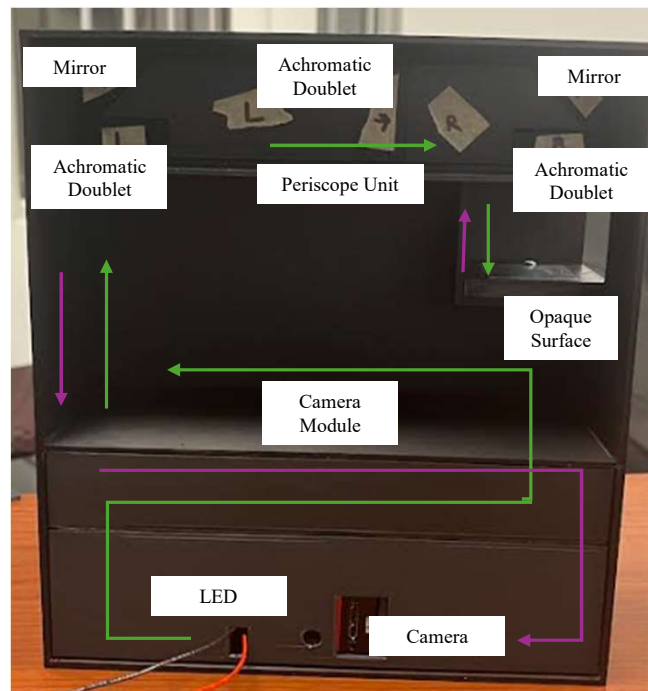

Inside Main Housing

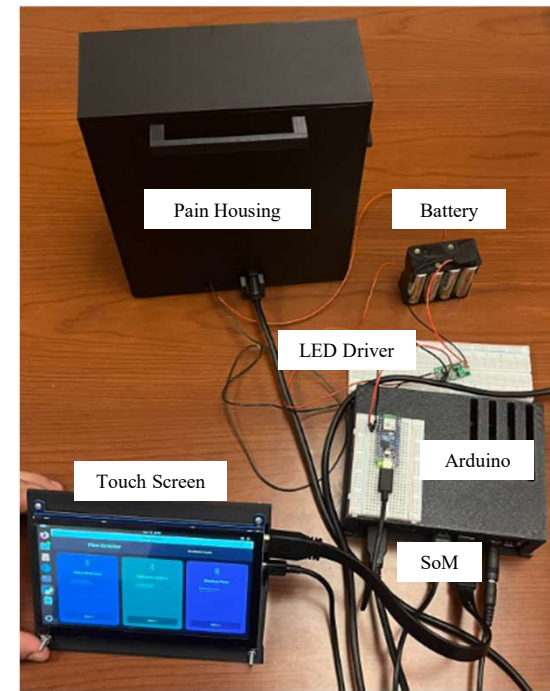

Overall Prototype

\*We cannot share system design calculations and dimensions due to a non-disclosure agreement with ASML\*

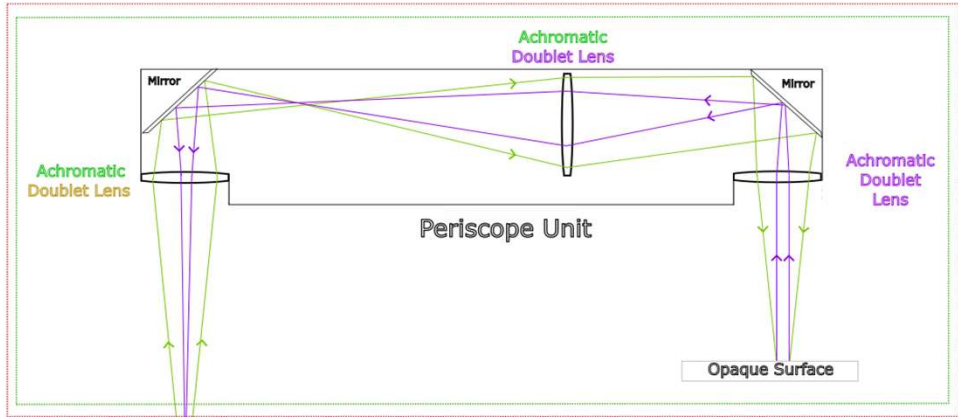

**KEY**  
 Reflected Image Optical Path ↑  
 Illumination Optical Path ↑  
 Kirolos : Darkfield Illumination  
 Julian : Image Detection

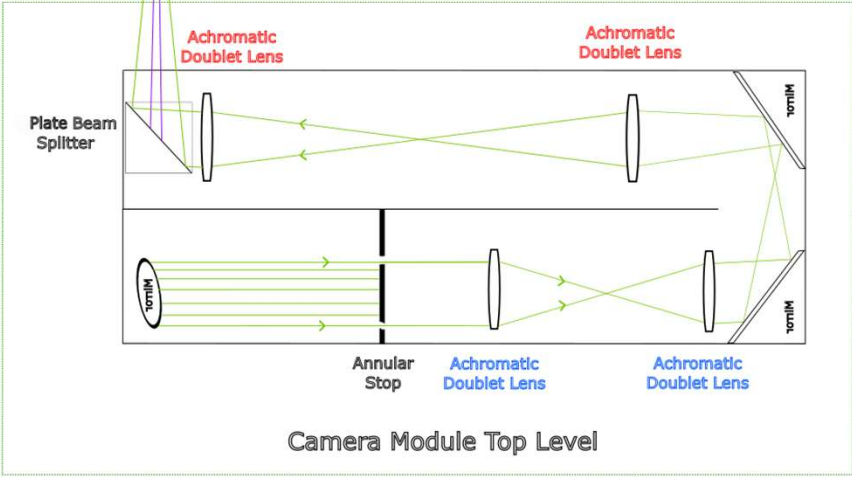
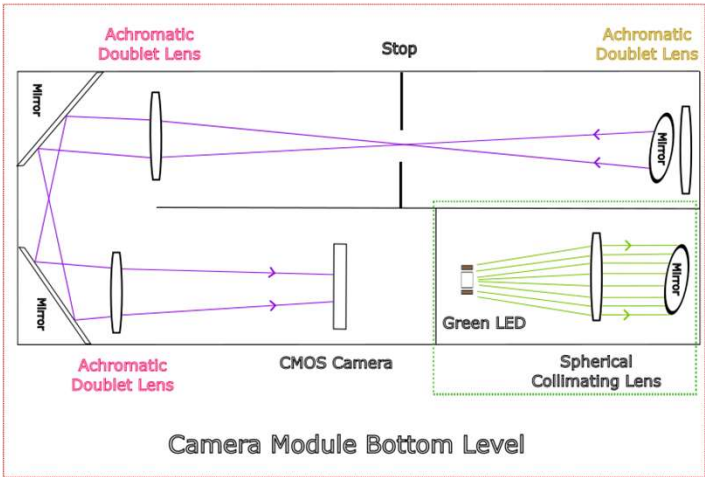

\*We cannot share system design calculations and dimensions due to a non-disclosure agreement with ASML\*

# Illumination Ray Trace

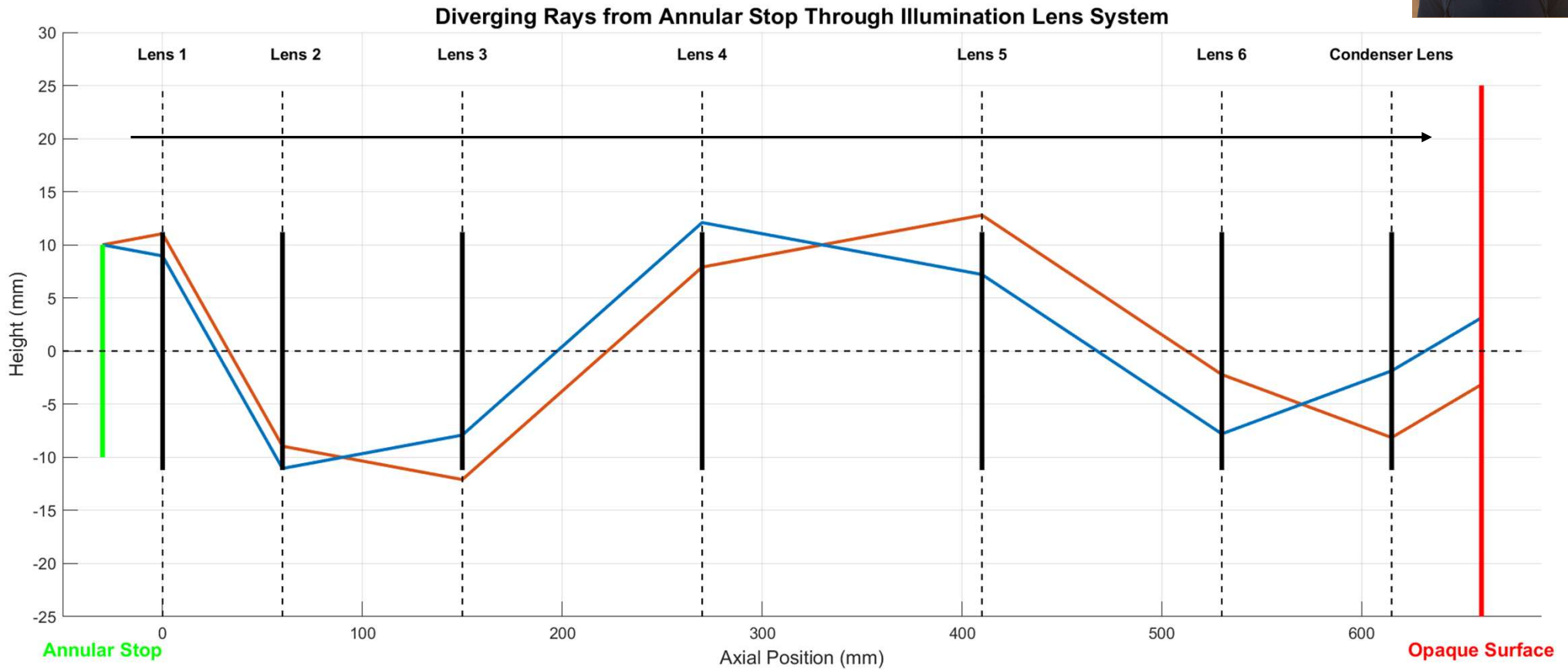

\*We cannot share system design calculations and dimensions due to a non-disclosure agreement with ASML\*

# Illumination Calculations

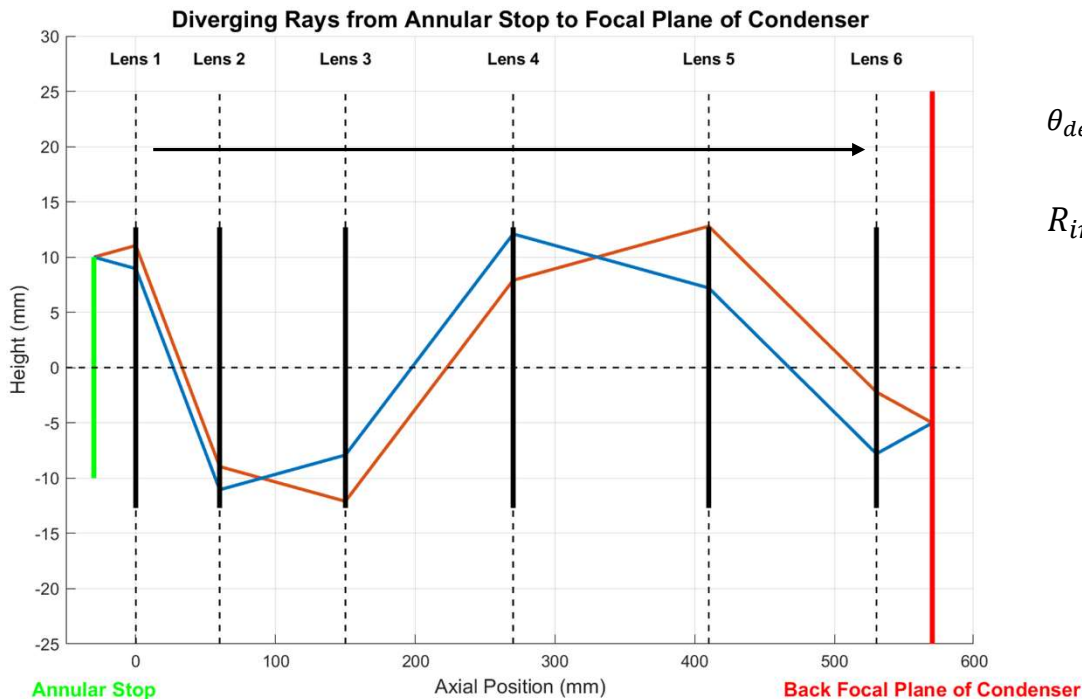

Annular Stop Size:

$$\theta_{\text{detection half-angle}} = \tan^{-1} \frac{R_{\text{lens WD}}}{\text{focal length}} \quad R_{PO} = \frac{\text{Outer radius}}{\text{Magnification}}$$

$$R_{\text{inner mask}} = f \tan \theta_{\text{detection half-angle}} \quad R_{PI} = \frac{\text{Inner radius}}{\text{Magnification}}$$

Magnification:

$$M_{I1} = \frac{f_2}{f_1} \quad M_{I2} = \frac{f_4}{f_3} \quad M_{I3} = \frac{f_6}{f_5}$$

$$M_{IT} = M_{I1} \times M_{I2} \times M_{I3}$$

Optical Path:

$$f_5 + 2f_6 + f_c \leq \text{Periscope Path length}$$

$$f_4 + f_5 \geq \text{Free space specification}$$

$$2f_1 + 2f_2 + 2f_3 + 2f_4 + 2f_5 + 2f_6 + f_c < \text{Total available path length}$$

\*We cannot share system design calculations and dimensions due to a non-disclosure agreement with ASML\*

# Detection Ray Trace

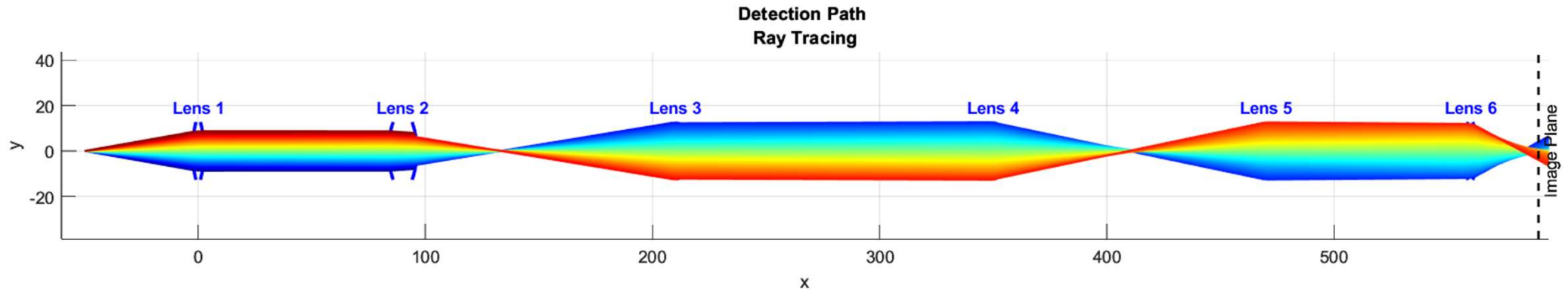

\*We cannot share system design calculations and dimensions due to a non-disclosure agreement with ASML\*

# Detection Calculations



*Calculated Numerical Aperture:*

$$NA = n \sin(\theta_a)$$
$$\theta_a = \arctan\left(\frac{\frac{D}{2}}{f}\right)$$

$$NA_{object} = n \sin\left(\arctan\left(\frac{\frac{D}{2}}{f}\right)\right)$$

*Conditions:*

$f_1 >$  Path length between periscope and surface

$f_3 + f_4 \geq$  Path length between modules

$2f_1 + 2f_2 + f_3 \leq$  Path length at periscope end

$2f_1 + 2f_2 + 2f_3 + 2f_4 + 2f_5 + 2f_6 <$  Total available path length

*Target Magnification:*

$$M_{total,detection} = \frac{\text{Sensor size}}{\text{Object area}}$$

*Magnification for our system:*

$$M_{d1} = \frac{f_2}{f_1}$$

$$M_{d2} = \frac{f_4}{f_3}$$

$$M_{d3} = \frac{f_6}{f_5}$$

$$M_{dT} = M_{d1} M_{d2} M_{d3}$$

\*We cannot share system design calculations and dimensions due to a non-disclosure agreement with ASML\*

# Periscope Unit

- 200 × 40 × 40 mm 3D printed periscope unit designed to redirect the optical path
- Holds mirrors and optical components in fixed alignment
- Allows camera placement outside the direct inspection path
- Compact design meets system size constraints
- Enclosed structure reduces ambient light interference

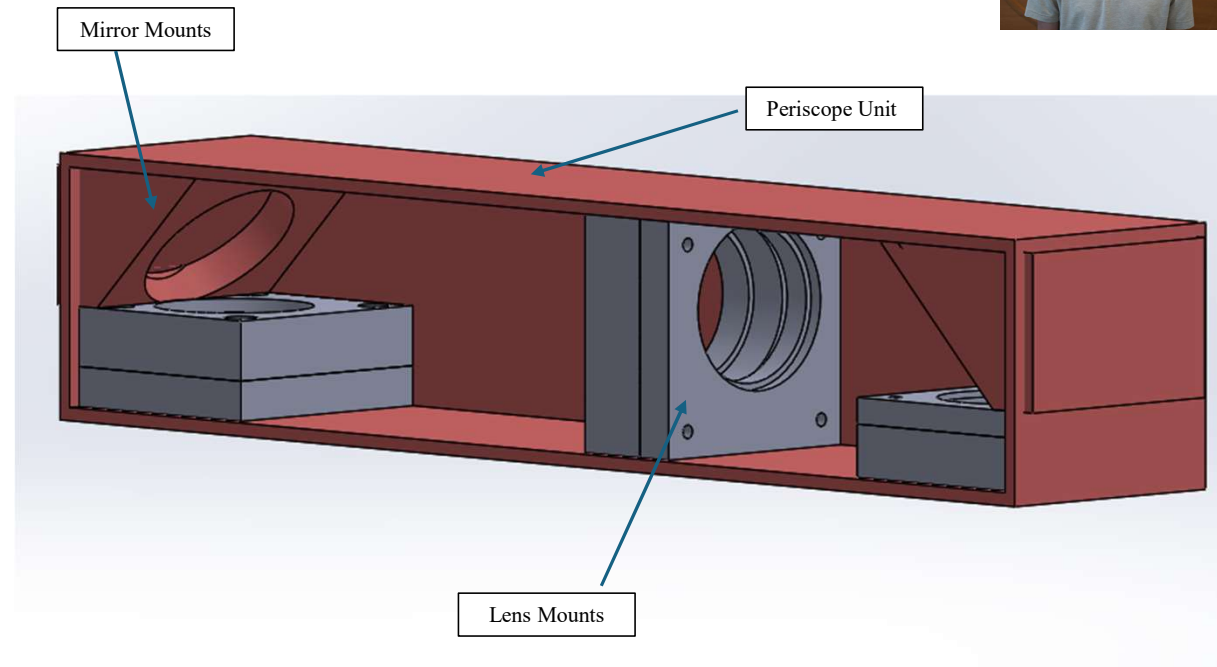

\*We cannot share system design calculations and dimensions due to a non-disclosure agreement with ASML\*

# Camera Unit

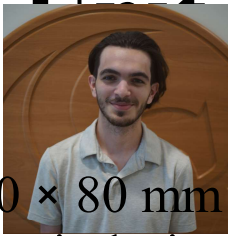

- 200 × 80 × 80 mm 3D printed camera unit designed to house and secure all optical mounts and components
- Maintains proper alignment of internal optical elements
- Split into upper and lower halves for easier assembly
- Two-piece design simplifies fabrication and component access
- Compact enclosure sized to meet project space constraints

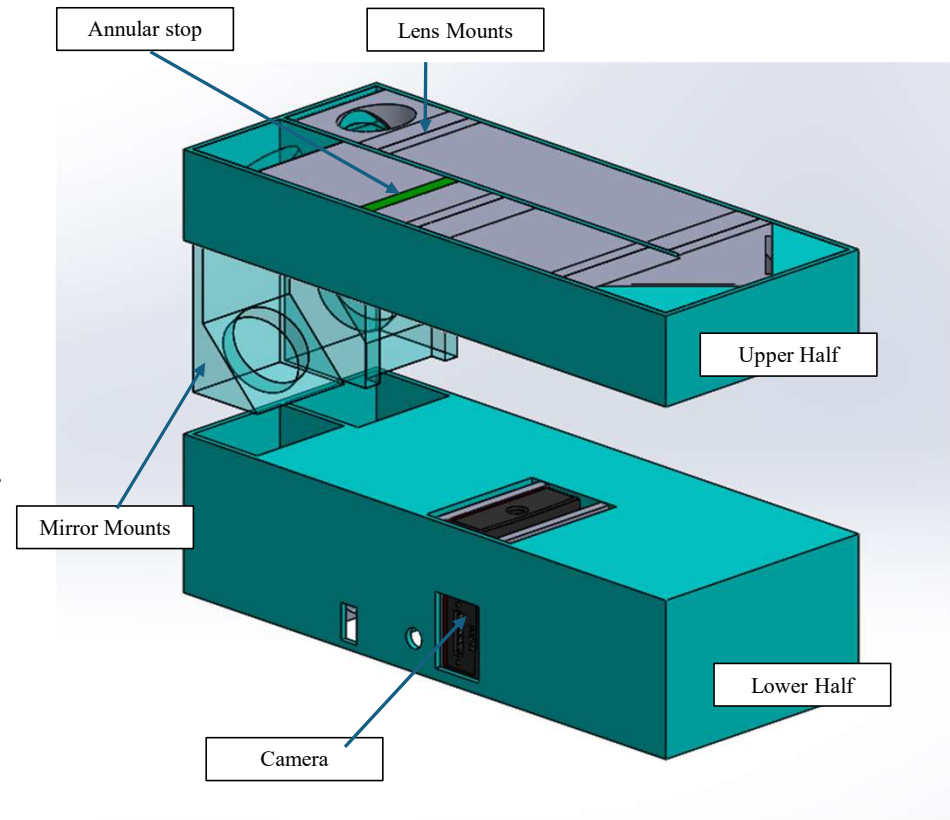

\*We cannot share system design calculations and dimensions due to a non-disclosure agreement with ASML\*

# Main Casing & Assembly



- Fully 3D printed main case designed with a modular structure
- Allows camera and periscope units to slide in and out for easy installation
- Maintains alignment between optical subsystems
- Enclosed housing provides a controlled environment and blocks ambient light
- Modular design simplifies assembly, maintenance, and future adjustments

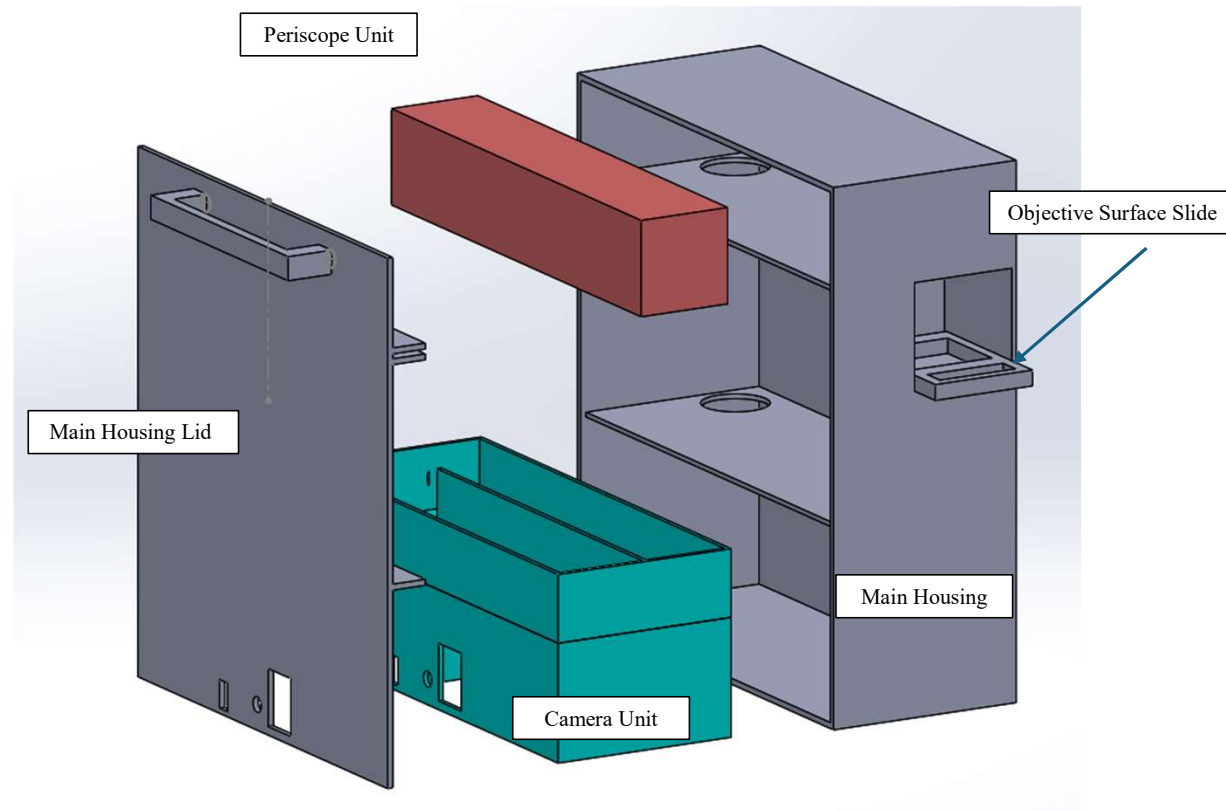

\*We cannot share system design calculations and dimensions due to a non-disclosure agreement with ASML\*



# Camera Adjusting Mechanism

Mechanism	Micrometer	Crank rocker	Series of gears and rack	Rail & slider
Cost	Relatively expensive	Minimal cost	Low cost	Low cost
Complexity	Simple construction	Moderately simple	Very simple	Moderately simple
Customizability	Limited	Highly customizable	Moderately customizable	Moderately customizable
Size	Large	Customizable but low	Customizable low	Customizable low
Availability	High	Custom Fabricaion Required	Medium	Medium
Accuracy	Very Precise	Dependent on Design Parameters	Sufficient for Application	Sufficient for Application
Smooth motion	Excellent	Acceptable	Consistent	Consistent

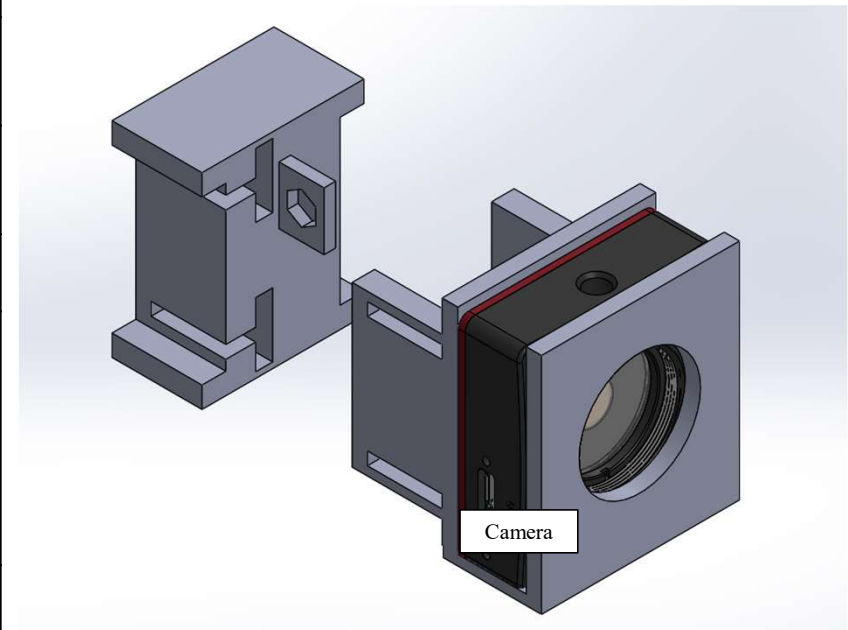

\*We cannot share system design calculations and dimensions due to a non-disclosure agreement with ASML\*



# Annular Stop

- 3D printed annular stop used to shape and control LED illumination path
- Three support arms designed to minimize obstruction of usable light
- Helps create dark field style illumination for improved particle visibility
- Compact component integrated directly into the camera housing assembly
- Designed for repeatable positioning and easy installation within the system

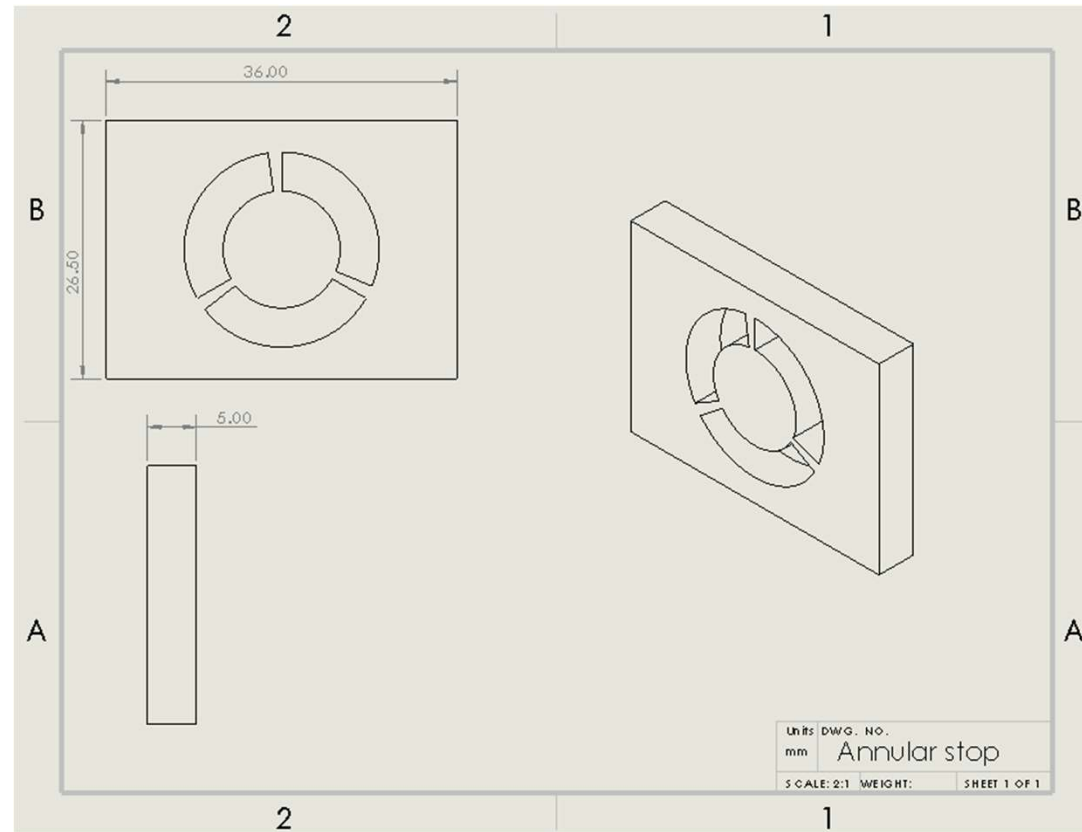

\*We cannot share system design calculations and dimensions due to a non-disclosure agreement with ASML\*

# Optical Mounts

- Custom 3D printed optical mounts designed to securely hold lens components in position
- Maintains alignment along the optical axis for consistent sized to fit selected
- Screw hole pattern allows secure & flush fastening
- Modular design allows easy removal, adjustment, or replacement during testing

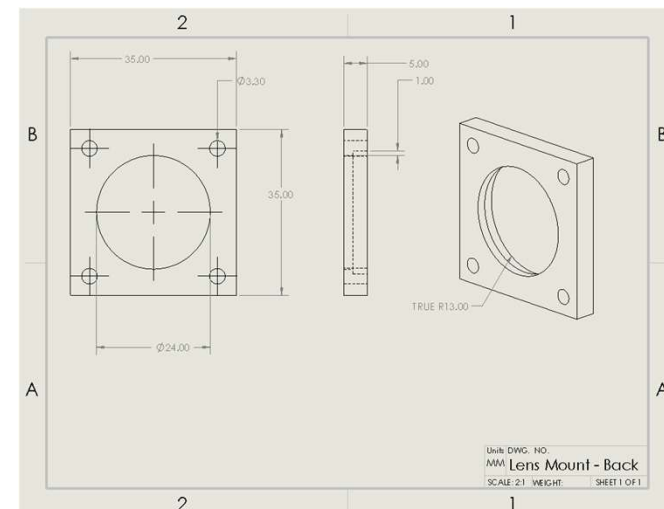
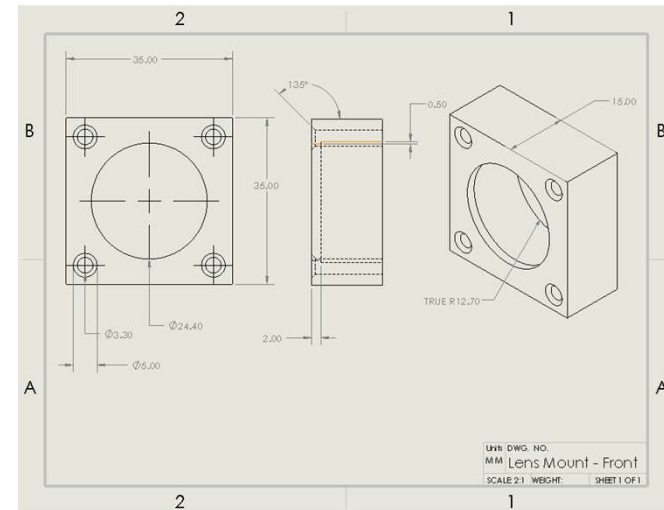

\*We cannot share system design calculations and dimensions due to a non-disclosure agreement with ASML\*



# Hardware Selection

# Camera Technology



- Camera technology desired characteristics:
  - Quality dynamic range
  - Low power consumption
  - Quality quantum efficiency
  - Resistance to overheating while using
- While CMOS sensors have higher noise and worse thermal performance, the difference between the technologies does not affect our project greatly.

Camera Sensor Technology	CCD (Charge-Coupled Device)	CMOS (Complementary Metal-Oxide-Semiconductor)
Signal Conversion	Single amplifier converts charge to voltage.	Each pixel has its own amplifier.
Noise Level	Lower noise, uniform	Higher noise
Signal Output	Analog; needs external digitization.	Digital; converted on-chip.
Quantum Efficiency	Historically higher.	Now comparable or higher.
Dynamic Range	Slightly lower in modern sensors.	Generally higher dynamic range.
Power Consumption	High.	Low; better for portable devices.
Thermal Performance	Cooler operation; ideal for long exposures.	Generates more heat; usually cooling not required.



# Camera Technology (Continued)

- Additional camera technology desired characteristics:
  - Lower cost
  - Wide availability
- Considering we are imaging a still target, both the CMOS sensor's higher frame rate and immunity to smear and bloom are trivial factors

Camera Sensor Technology	CCD (Charge-Coupled Device)	CMOS (Complementary Metal-Oxide-Semiconductor)
Smear/Bloom Effect	Susceptible to image artifacts.	Immune to smear and bloom.
Speed / Frame Rate	Slower readout.	Faster readout.
Manufacturing Cost	Expensive, complex fabrication.	Cheaper, standard process.
Cooling Needs	Often cooled for precision imaging.	Rarely needed; CMOS offers cooled option.
Typical Use	Scientific, medical, industrial imaging.	Consumer, mobile, automotive applications.
Market Trend	Declining use.	Dominant due to cost and efficiency.

# Camera Selection



- Camera desired characteristics:
  - Large sensor size
  - Resolution
  - Larger pixel size
- The size of particle we are inspecting is not close in size to the diffraction limit of our optics, making the larger 3.45  $\mu\text{m}$  pixel size ideal and the 1.6 MP resolution sufficient
- While a larger sensor size lessens the design constraints for this project, the 4.968 mm x 3.726 mm is sufficient

Camera	IDS U3-3880CP C HQ	Thorlabs CS165CU	Teledyne DR-U3-50Y2C-C1-C S
Sensor size / format	1/1.8" (8.9 mm diagonal) – sensing area 7.411 mm $\times$ 4.982 mm	1/2.9" (6.2 mm diagonal) – imaging area 4.968 mm $\times$ 3.726 mm	1/2.5" (6.4 mm diagonal) – imaging area $\sim$ 5.70 mm $\times$ 4.28 mm
Resolution (pixels)	3088 $\times$ 2076 (6.41 MP)	1440 $\times$ 1080 (1.6 MP)	2592 $\times$ 1944 (5.0 MP)
Pixel size	2.40 $\mu\text{m}$ $\times$ 2.40 $\mu\text{m}$	3.45 $\mu\text{m}$ $\times$ 3.45 $\mu\text{m}$	$\sim$ 2.2 $\mu\text{m}$ $\times$ 2.2 $\mu\text{m}$
Shutter type	Rolling	Global shutter	Rolling
Max frame rate (full resolution)	$\sim$ 59 fps	$\sim$ 34.8 fps	$\sim$ 49 fps
Dynamic range	$\sim$ 71 dB	Up to $\sim$ 69 dB	$\sim$ 69 dB
Quantum efficiency (peak)	Not specified	$\sim$ 65% at 535 nm	$\sim$ 74% at 525 nm, $\sim$ 65% at 470 nm, $\sim$ 48% at 630 nm



# Camera Selection (Continued)

- Additional camera desired characteristics:
  - Housing size
  - Exposure time range
  - Power consumption
- Due to our strict size constraints, selecting a camera size near 40 mm x 40mm was necessary
- The large range of exposure time for the CS165CU ensures that no matter the lighting condition the camera will be able to take a quality image
- The minimal 1.17 W power consumption enables the longest battery life for our system

Camera	IDS U3-3880CP C HQ	Thorlabs CS165CU	Teledyne DR-U3-50Y2C-C1-C S
Housing / physical size	29 mm × 29 mm × 29 mm (excluding connectors/lens mount)	~43.7 mm × 47.2 mm × 20.7 mm	29.5 mm × 29.5 mm × 23 mm
Exposure time range	0.014 ms – 1060 ms	0.040 ms – 26,843 ms	0.009 ms – 500 ms
Interface type	USB 3.0	USB 2.0	USB 3.1 Micro-B
Software / SDK	IDS peak SDK (USB3 Vision compatible)	ThorCam	Spinnaker SDK
Power consumption	~1.4 – 3 W	1.17 W	2.4 W max
Cost	\$515.04	\$513.45	\$199.00

# Lens Technology



- Lens technology desired characteristics:
  - Minimal chromatic and spherical aberration
  - Minimal Alignment Sensitivity
- Achromatic doublets provide the best trade off between minimizing chromatic aberrations, cost, and difficulty with alignment

Lens Type	Singlet	Achromatic Doublet	Apochromat
Chromatic correction	Poor	Moderate (2 wavelengths)	Excellent (3+ wavelengths)
Spherical aberration	Moderate	Moderate-Low	Low
Cost	Low	Medium	High
Complexity	Simple	Moderate	High
Alignment sensitivity	Low	Moderate	High
Common applications	Laser collimation, monochromatic imaging	General visible imaging, relay systems	Precision imaging, microscopy, broadband systems



# Opaque Surface Selection

- Opaque surface desired characteristics:
  - High reflectivity
  - Availability
  - Low surface roughness
- Aluminum has high reflectivity, is widely available, and has low surface roughness
- Stainless steel has higher durability but more diffuse scattering

Surface	Stainless Steel	Aluminum	Silicon Wafer	Copper
Reflectivity	High (polished)	Very high	Extremely high	Moderate-high
Surface Roughness	Medium-low	Low	Very low	Low (polished)
Specular Reflection	Moderate-high	High	Very high	High (fresh)
Diffuse Scattering	Medium	Low	Very low	Increases with oxidation
Durability	Very durable	Soft, scratches easily	Fragile	Soft, scratches
Cost	Low- Medium	Low	High	Medium
Availability	High	Very high	Limited	Moderate
Maintenance	Low	Low	Low	High
Color / Contrast	Neutral gray	Bright silver	Dark gray	Red-orange

# Particle Selection



- Particle desired characteristics:
  - Within target size
  - Low absorption
  - Availability
- Having our particles being within the target size range is the most important feature
- Ideally, we would use a particle with lower absorption than human hair but measuring the exact size of those particles is difficult

Criterion	Cotton Fiber	Human Hair	Cellulose Fiber
Typical Length	5–12 mm (cut to test size)	50–100 mm (cut to test size)	0.5–3 mm (can be cut)
Diameter	12–20 $\mu\text{m}$	50–100 $\mu\text{m}$	10–20 $\mu\text{m}$
Reflectivity	Very low	Low–moderate	Very low
Scattering Type	Mostly diffuse	Mostly diffuse	Diffuse
Surface Texture	Twisted, matte	Smooth, cylindrical	Irregular, fibrous
Relevance as Contaminant	Very common textile contaminant	Common biological/environmental contaminant	Common paper/packaging contaminant
Why It is Useful for Testing	Soft diffuse signature	Thick, high-contrast fiber	Very small, low-contrast fiber



# Illumination Source Technology

- Illumination source desired characteristics:
  - Output high optical power
  - Low coherence
  - Compact enough to fit in our housing
- Halogen and arc lamps require cooling hardware that makes them too big to integrate
- Laser's high coherence is not ideal for darkfield applications
- LED was chosen due to its high-power efficiency, low coherence and compact size

Light Source Type	Collimation	Coherence	Bandwidth	Power Efficiency	Integration	Cost
Halogen Lamps	Low	Low	Very Wide	Very Low	Challenging due to dimensions	\$15-\$100
Arc Lamps	Low	Low	Wide	Low	Challenging due to dimensions	\$200-\$800
LEDs	Low	Low	Moderate	High	Ideal	\$1-\$100
Lasers	High	Narrow	Very High	Very High	Challenging due to dimensions	\$25-\$200



# Illumination Source Selection

- Green wavelength is chosen due to its low aberration performance when used with achromatic doublets
- High power is chosen since the optical system loses a lot of power from collimation, annular stop, lens system, beamsplitter and mirrors
- All the LEDs we compared had similar specifications
- We chose the LED from CHANZON due to its higher luminous flux and the inclusion of engineering diagrams

Green LED	Input Voltage	Input Current	Wavelength	Viewing Angle	Luminous Flux	Integration	Cost
Green 10W High Power LED by Switch Electronics (311448)	11 V	900 mA	520 – 525 nm	140°	650 Lumens	Challenging due to lack of driver	\$8.12
10 Watt Green LED by Vetco Electronics (VUPN1856)	9 – 12 V	900 mA	520 – 525 nm	140°	700 Lumens	Challenging due to lack of driver	\$8.95
High Power LED Chip 10W Green by CHANZON	9 – 12 V	840 – 1000 mA	520 – 525 nm	140°	800 Lumens	Ideal	\$6.99

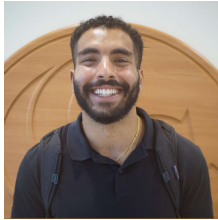

# Collimating Lens Technology

- Collimating lens needed to convert diverging LED rays into parallel beam
- Illumination source desired characteristics:
  - Low Divergence
  - Short focal length
  - High beam quality
- Aspheric lenses rejected despite high quality due to high cost
- Best form spherical lens selected for high beam quality at moderate cost

Lens Type	Beam Collimation Quality	Minimum Focal Length Available	Spherical Aberration Compensation	Cost
Aspheric Lens	High	20 mm	High	\$200 – \$2000
Best Form Spherical Lenses	High	40 mm	Medium	\$40 – \$100
Plano-Convex	Medium	25 mm	Low	\$20 – \$100

# Collimating Lens Selection

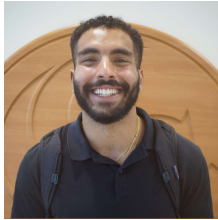

- LBF254-040-A chosen for its 40mm focal length and AR coating (350 nm – 700 nm) matching the green LED
- AR coating only adds about \$13 and increases beam power with no burn risk from the 10W LED

Lens	Beam Collimation Quality	Focal Length	Coating	Cost
LBF254-040	High	40 mm	N/A	\$54.67
LBF254-040-A	High	40 mm	350 nm – 700 nm AR	\$67.06
LBF254-040-B	High	40 mm	650 nm – 1050 nm	\$67.06

# Optical Mirror Technology



- Optical mirror desired characteristics:
  - High reflectance in the visible spectra
  - Low distortion
  - Compact size to fit in the housing
  - Low cost due to the total of 10 mirrors in our project
- Back-surface plano mirrors have a lot of distortion and ghosting
- Right-angle prism mirrors are too big for the housing
- We chose front-surface plano dielectric mirrors for their compact size, low distortion and higher reflectance compared to metallic mirrors

	Reflectance	Wavelength	Integration	Cost
Front-Surface Plano Metallic Mirrors	85% – 98%	250 nm – 20 $\mu$ m	Low Effort	\$40 – \$200
Front-Surface Plano Dielectric Mirrors	>99%	400 nm – 750 nm	Low Effort	\$80 – \$200
Back-Surface Plano Mirrors	>99%	450 nm – 20 $\mu$ m	Low Effort	\$80 – \$130
Right-Angle Prism Mirrors	>99%	400 nm – 750 nm	Ideal	\$70 – \$320

# Optical Mirror Selection

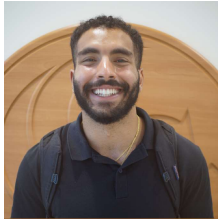

- BB111-E02 is Zerodur coated for low thermal expansion
- BB1-E02 is chosen for its lower cost since the project does not include a high-power laser that might cause thermal expansion

Mirror Type	Reflectance	Wavelength	Integration	Cost
BB1-E02	>99%	400 nm – 750 nm	Low Effort	\$86.91
BB111-E02	>99%	400 nm – 750 nm	Low Effort	\$143.64

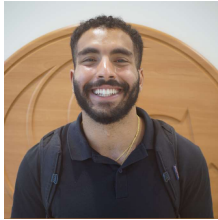

# Beamsplitter Technology

- Beamsplitter desired characteristics:
  - 50:50 (R:T)
  - Low ghost reflections
  - Low beam displacement
  - Compact size to fit in the housing
- Cube beamsplitters are too big for the housing
- Pellicle beamsplitters perform better but are too fragile
- We chose a plate beamsplitter for its moderate performance and high durability

Beamsplitter Type	Split Ratio (R:T)	Wavelength	Ghost Reflections	Beam Displacement	Polarization Dependence	Integration	Cost
Plate Beamsplitters	50:50	400 nm – 700 nm	Moderate	Moderate	High	Low Effort	\$90 – \$300
Cube Beamsplitters	50:50	400 nm – 700 nm	Low	Low	Moderate	None	\$190 – \$600
Pellicle Beamsplitters	45:55	400 nm – 700 nm	Low	Low	Moderate	Low Effort	\$200 – \$300

# Beamsplitter Selection

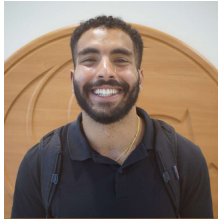

- BSW41-532 is designed to be used with Nd:YAG lasers
  - Narrow band of expected performance
- BSW10 is chosen for its high performance across the visible spectra and lower cost

Beamsplitter Type	Split Ratio (R:T)	Wavelength	Integration	Cost
BSW10	50:50 at 525 nm	400 nm – 700 nm	Low Effort	\$122.03
BSW41-532	50:50 at 532 nm	532 nm	Low Effort	\$373.85



# Filament Selection

•**PLA-CF** Chosen for the camera housing, periscope unit, and internal mounts due to its increased stiffness and dimensional stability

•**PLA:** Used for the outer housing because it is cost effective, easy to print, and sufficient for structural support

Filament Type	Strength	Density	Stiffness	Heat Resistance	Toughness	Adhesion
PLA	76MPa	1.20–1.30 g/cm <sup>3</sup>	2750MPa	57°c	26.6kJ/m <sup>2</sup>	13.8kJ/m <sup>2</sup>
PLA CF	89MPa	1.30–1.50 g/cm <sup>3</sup>	3950MPa	55°c	23.2 kJ/m <sup>2</sup>	7.8kJ/m <sup>2</sup>
ABS	62MPa	1.01–1.10 g/cm <sup>3</sup>	1880MPa	87°c	39.3 kJ/m <sup>2</sup>	7.4kJ/m <sup>2</sup>
TPU	N/A	1.10–1.25 g/cm <sup>3</sup>	N/A	69°c	124.2 kJ/m <sup>2</sup>	8.73kJ/m <sup>2</sup>



# Processor Technology

- SoM was the best option given the high computing power.
- Ease of integration played an important role as off-the-shelf component requirements ruled out custom MCU board

Technology	Computing Power	Integration Effort	Size / Power	Ecosystem	Image-Processing Suitability
MCU	Low	Very Easy	Minimal	Limited	Poor
SBC	Very-High	Moderate	Large / High	Excellent	Excellent
SoM	High	Slightly Easy	Compact / Moderate	Strong	Very Good



# Processor Selection

- Chose the LattePanda Mu.
- Originally selected the Raspberry Pi CM5. Forced to look for alternatives due to CPU architecture:
  - Raspberry Pi CM5 utilizes an ARM architecture chip.
  - This architecture is not compatible with the proprietary Thorlabs code for the Camera
  - LattePanda Mu runs on a x86 chip which is compatible.

Technology	CPU	Memory	Cost	Ecosystem	Image-Processing Suitability
ArmSoM CM5	Rockchip RK3576: 4× Cortex-A72 @ 2.2 GHz + 4× Cortex-A53 @ 1.8 GHz	Up to 16 GB LPDDR5	Moderate / High	Limited	Good
LattePanda Mu	Intel N100 (or N305) x86; quad-core up to 3.4 GHz (N100)	8-16 GB LPDDR5	Moderate / High	Moderate	Excellent
Raspberry Pi CM5	Broadcom BCM2712, 4× Cortex-A76 @ up to 2.4 GHz (Armv8)	LPDDR4X 2/4/8/16 GB	Moderate	Strong	Excellent



# Display Technology

- Biggest contributing factor was cost
- LCD technology being more cost effective was important as:
  - There is limited input required from the user
  - Software saves results as .pngs, thus being transferrable and viewable on other devices if required
- Better durability also strongly impacted decision

Technology	Image Quality	Durability	Suitability	Cost
LED	Very high contrast, deep blacks	Can suffer burn-in	Premium, high-end visuals	High
OLED	Highest contrast, deepest blacks	More susceptible to burn-in	Top of the market visuals	Very High
LCD	Excellent color accuracy, slightly lower contrast	No burn-in, longer lifespan	Reliable, cost-effective embedded use	Moderate

# Touch Input Technology



- Decided on capacitive mainly for better clarity
- Additionally, higher durability was important
- Not the most impactful on our final technology selection

Technology	Input Type	Multi-Touch Support	Clarity	Durability	Cost
Resistive	Pressure-based	No	Moderate	Moderate	Lower
Capacitive	Conductive	Yes	Excellent	High	Slightly High



# Screen Size Selection

- Dimensions of our project affected panel size selection
- Medium Panel was the best compromised:
  - Allowed for better viewing of image while not taking too much space
  - Price difference between medium and small was not too substantial

Technology	Resolution	Touch Type	Interface & Power	Cost
Large Panel	1920×1080 or higher	Capacitive	HDMI + power >5 V	High
Medium Panel	1024×600	Capacitive	HDMI + USB + 5 V	Moderate
Small Panel	800×480	Capacitive or resistive	HDMI or SPI/DSI	Low

# Touch Screen Selection



- Waveshare was selected primarily thanks to its higher levels of documentation
- Brand recognition also added to confidence in the product

Technology	Brand / SKU	Pros	Cons
BuyDisplay 7" IPS 1024x600 HDMI	Generic / BuyDisplay	Lower cost; flexible module	Possibly minimal mounting support; touch driver may require more setup
Waveshare 7" HDMI LCD IPS 1024x600 Touch	Waveshare	Strong brand; known SoM compatibility; good documentation	Slightly higher cost; may need manual configuration tweaks
52Pi / iPistBit 7" 1024x600 HDMI Touch	52Pi / iPistBit	Ready for SoM; includes frame and stand	Possibly less optimized for custom embedded enclosure; may add size/mass



# LED Microcontroller Technology Selection

- All three were very viable options to integrate into our project
- Arduino Nano was select since it has a lower price than the Arduino Uno as well as ample documentation when compared to the MCP2221A

Product	Size	Operating Voltage	Ease of Integration	GPIO Pins	Price
Arduino Nano ESP32 [ABX00083]	Small	3.3V	High	Yes	Medium
MCP2221A USB to GPIO	Smallest	3V	Moderate	Yes	Low
Arduino Uno REV3 [A000066]	Medium	5V	High	Yes	Medium High

# Power Distribution



Component	Working Voltage (DC)	Working Current	Working Power
LattePanda Mu	9-20 V	3 A	> 10W (> 45W for carrier board)
Waveshare 7" HDMI LCD IPS 1024x600 Touch	5 V	2.5-3 A	~15 W
Arduino Nano ESP32 [ABX00083]	5V	2.5-3A	~15 W
Thorlabs CS165CU	5V	2.5-3A	~15 W
High Power LED Chip 10W Green by CHANZON	9-12 V	840-100mA	10W

- LattePanda Mu to be powered by AC/DC power supply
- Screen, Camera, and Arduino to be powered via USB from LattePanda Mu
- LED requires constant current driver
  - Requires its own power supply

# Constant Current Driver Selection



- Difficulties finding off-the-shelf drivers that met all our requirements
- LD24AJTA was chosen as it can output the desired current (900mA)
- Only option that was programmable
  - Contains PWM pins
- Also outputs desired power (10W)
- Works with DC batteries

Product	Working Voltage	Output Current	Output Power	Programmable
LD24AJTA Constant Current LED Driver	DC 6-25 V	30-1200mA	Up to 20W	Yes
Ironsmith Lighting Products - Constant Current LED Driver Transformer	AC 120 V	2000mA	42W	No
B0F1K97V61 Constant Current Led Driver	DC 2.9-6.1V	28-1500mA	Up to 8W	No



# Battery Technology Selection

- Selected NiMH batteries primarily due to:
  - Easy portability
  - Safe to use
  - Lower cost

Technology	Nominal Cell Voltage	Energy Density (Wh/kg)	Recharge Cycles	Safety / Complexity	Typical Cost per Wh	Suitability
Li-ion (18650)	3.6 - 3.7 V	180 - 250	500 - 1000	Requires BMS & protection	Moderate	Excellent but complex
NiMH (AA)	1.2 V	60 - 120	500 - 800	Very safe & simple	Low	Very Good for moderate load
SLA	2V per cell	30 - 40	200 - 300	Safe but heavy / bulky	Low	Poor for portable use



# Battery Selection

- Suitability for all products was good
- Selected the Amazon Basics primarily because of price

Product	Capacity (mAh)	Max Continuous Current	Cycle Life (cycles)	Price (8 pack)	Self-Discharge (after 1 year)	Suitability
Panasonic Eneloop Pro	2500	$\approx 2.5$ A	$\sim 500$	$\sim \$25$	$\sim 85\%$	Excellent; high current, stable voltage
Amazon Basics High Capacity	2400	$\approx 2$ A	$\sim 500$	$\sim \$15$	$\sim 80\%$	Very Good; cost-effective
Energizer Recharge Power Plus	2000	$\approx 1$ A	$\sim 400$	$\sim \$20$	$\sim 70\%$	Good; for light loads only

# Electrical Diagram

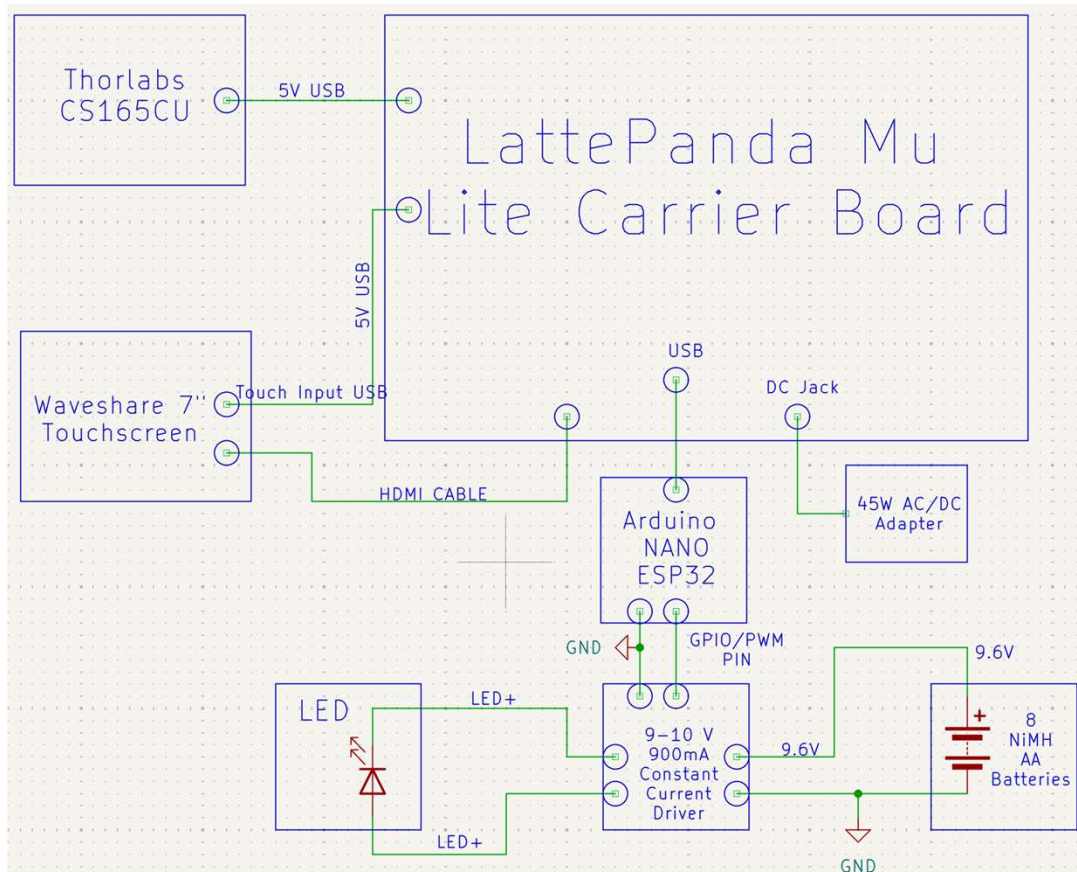

- Arduino, Touchscreen, Thorlabs camera all powered by LattePanda Mu via USB
- LED has its own power supply



# Software Selection

# Optical Simulation Software



- We will be using the optical simulation for:
  - Back reflection calculations
  - Ghost analysis
  - Ray stop diagram
  - Ray fan plots
- We chose Zemax due to our prior experience, high calculation efficiency, and high amount of available resources

Optical Simulation Software	Calculation Efficiency	Data Visualization	Resources	Prior Experience	Cost
Zemax	High	High	High	Moderate	Free as student
Code V	Ideal	High	Moderate	None	Need to request quote
3DOptics	High	Moderate	Moderate	None	\$40/month for students



# Data Analysis Software

- We will be using the data analysis software for:
  - Ray trace calculations
  - Ray trace plotting
  - Design calculations
- MATLAB selected for superior visualization, calculation efficiency, and team familiarity

Data Analysis Tool	Calculation Efficiency	Data Visualization	Resources	Prior Experience	Cost
Python	High	Moderate	High	Moderate	Free
<b>MATLAB</b>	<b>High</b>	<b>High</b>	<b>High</b>	<b>High</b>	<b>Free as student</b>
Excel	Low	Low	High	High	Free as student



# CAD Software Selection

- **SolidWorks** was selected as the primary CAD software for all mechanical component design
- **Strong assembly tools** allowed full system fitment and alignment checks before fabrication
- **Familiar software** platform reduced development time and improved workflow efficiency

Software	Ease of Use	3D Modeling Familiarity	Simulation Familiarity	3D Printing Compatibility	Native Manufacturer File Support	Cost
Fusion 360	Moderate	Moderate	Basic	Full	Limited	Free
<b>SolidWorks</b>	<b>Very intuitive</b>	<b>High</b>	<b>Strong</b>	<b>Full</b>	<b>Extensive</b>	<b>Free</b>
AutoCAD	Requires experience	Limited	None	Full	Good	Free

# Slicing and 3D Printing Software



- **Ultimaker Cura** was selected for preparing all 3D printed components
- **User friendly interface** with reliable print setup and toolpath generation
- **control** of layer height, wall thickness, infill, and print speed
- **Compatible** with available printers, making prototyping fast and efficient

Software	Ultimaker Cura	Slic3r	PrusaSlicer
User Interface	Very intuitive and beginner-friendly	Technical and less intuitive	User friendly with advanced options
Customization Level	Moderate, sufficient for most applications	Extensive, fine control over all parameters	High, advanced settings with guided options
Printer Compatibility	Extremely broad, supports most printers	Broad, but requires manual configuration.	Broad, supports most printers
Feature Set	Comprehensive basic and intermediate tools	Highly detailed parameter control and scripting	Comprehensive basic and intermediate tools
Visualization Tools	Strong, clear previews and error detection	Moderate, basic G-code visualization	Advanced, detailed layer and support visualization
Learning Curve	Very easy to learn	Steep, suited for experienced users	Moderate, accessible for most users



# Programming Language Selection

- When selecting the language for our software, all three were viable options
- Python was selected primarily due to its wide berth of libraries for particle detection and GUI design.
- Loss of speed between Python and the other options were not deemed to be significant enough

Language	Strengths	Limitations	Prior Experience
C	<ul style="list-style-type: none"><li>• Highest performance</li><li>• Tiny memory footprint</li><li>• Direct register-level access</li><li>• Vendor HAL/SDK support is ubiquitous</li></ul>	<ul style="list-style-type: none"><li>• Development is slower</li><li>• More boilerplate</li><li>• Harder to maintain at scale</li><li>• Fewer high-level libraries for vision/ML</li></ul>	High
C++	<ul style="list-style-type: none"><li>• Abstraction and modularity for complex systems</li><li>• Type safety</li><li>• Good performance near C with careful use.</li></ul>	<ul style="list-style-type: none"><li>• Some features complicate real-time behavior without strict guidelines</li><li>• More complex toolchains</li><li>• Potential code size growth.</li></ul>	High
Python	<ul style="list-style-type: none"><li>• Fast prototyping</li><li>• Rich ecosystems for CV/ML/data (NumPy, OpenCV, PyTorch/TFLite)</li><li>• Excellent on embedded Linux</li><li>• Easy integration with C/C++ via bindings.</li></ul>	<ul style="list-style-type: none"><li>• Not deterministic</li><li>• Interpreter and GC add latency</li><li>• Heavier memory footprint than C/C++</li><li>• Pure-Python loops are slower.</li></ul>	High

# Development Environment Selection



- Most experience with VS Code
- Familiarity with its extensions
- Ample support from the community

Environment	Strengths	Limitations	Prior Experience
PyCharm	<ul style="list-style-type: none"><li>• Excellent Python support</li><li>• Integrated debugger</li><li>• Built-in virtual environment tools</li><li>• Good project organization</li></ul>	<ul style="list-style-type: none"><li>• More resource-intensive</li><li>• Less convenient for C/C++ work</li><li>• Professional version has paid features</li></ul>	None
Eclipse	<ul style="list-style-type: none"><li>• Strong debugging</li><li>• Large plugin ecosystem</li></ul>	<ul style="list-style-type: none"><li>• Heavy</li><li>• Outdated UI</li><li>• Steep learning curve</li></ul>	Moderate
VS Code	<ul style="list-style-type: none"><li>• Lightweight</li><li>• Highly customizable</li><li>• Supports Python + C/C++</li><li>• Remote development</li><li>• Strong extensions</li></ul>	<ul style="list-style-type: none"><li>• Requires extension setup</li></ul>	High

# Software Block Diagram

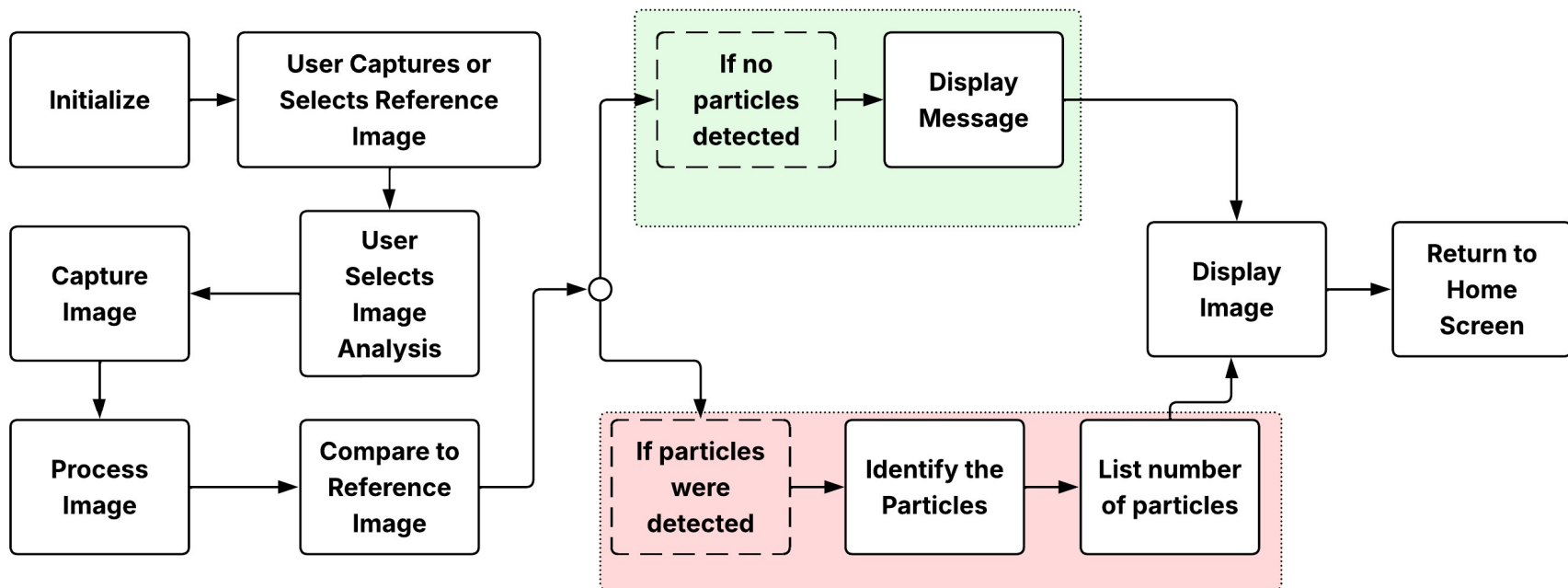

# Use Case Diagram

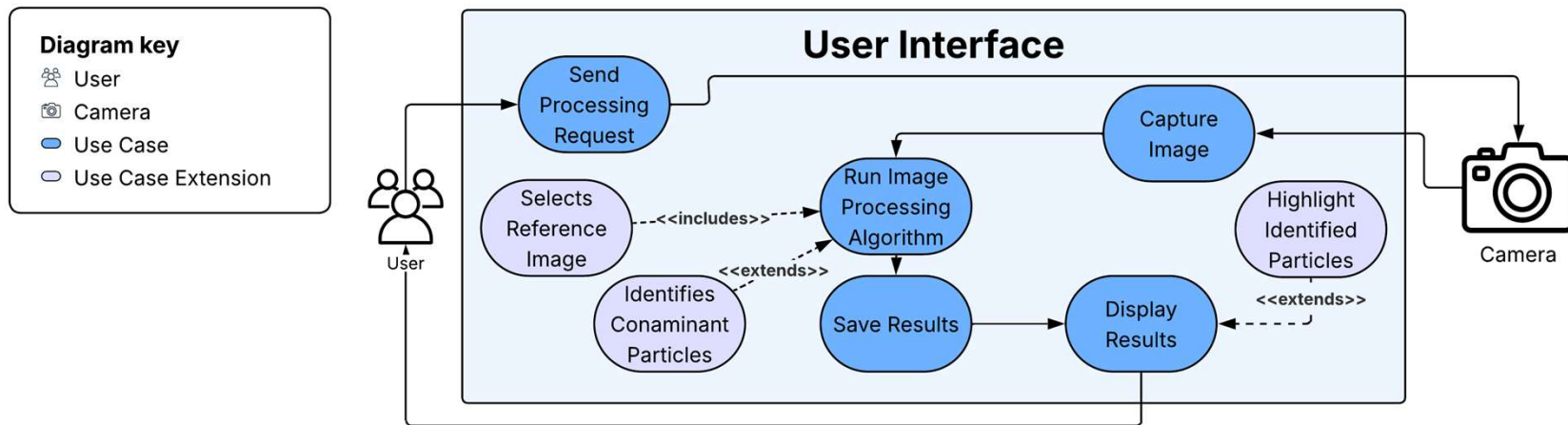

# App Home Screen UI

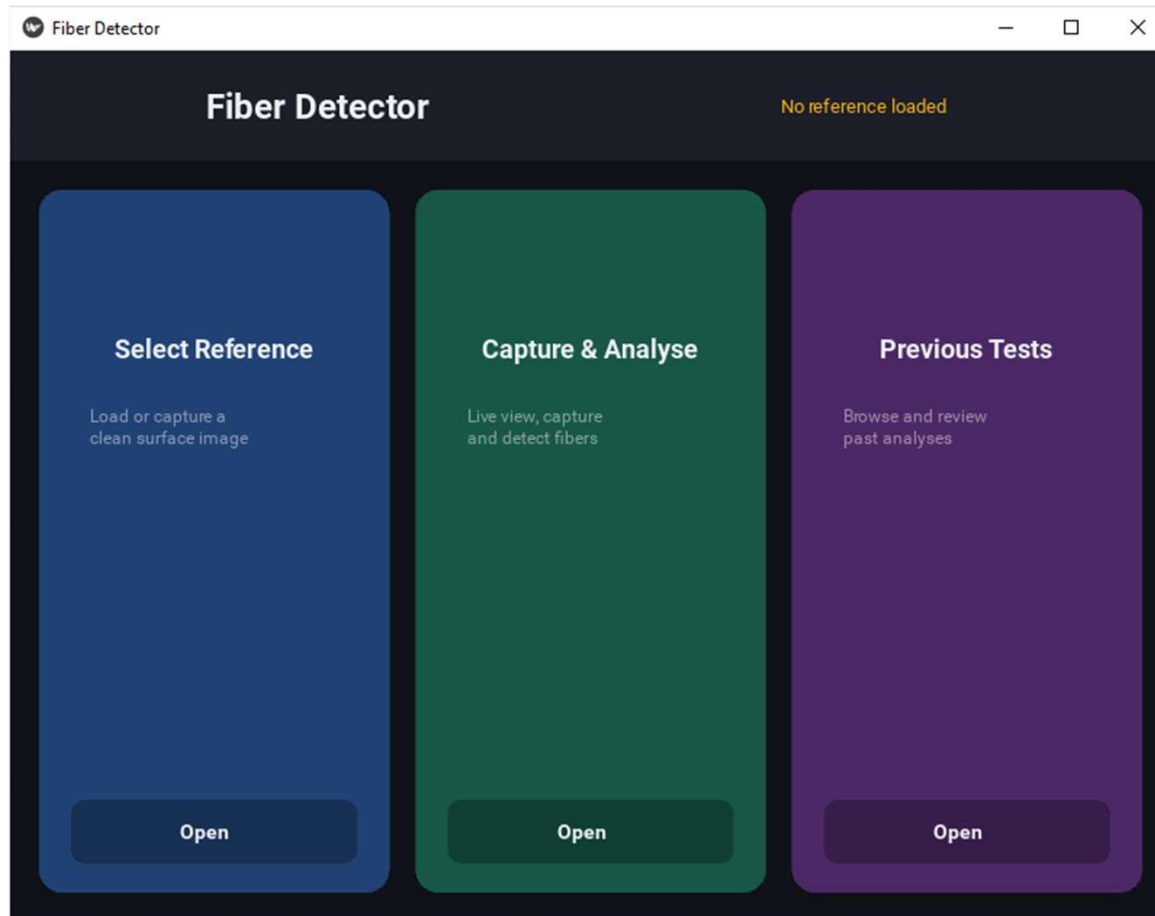

- Simple design
- Easy access to all 3 options

# App Reference Screen UI

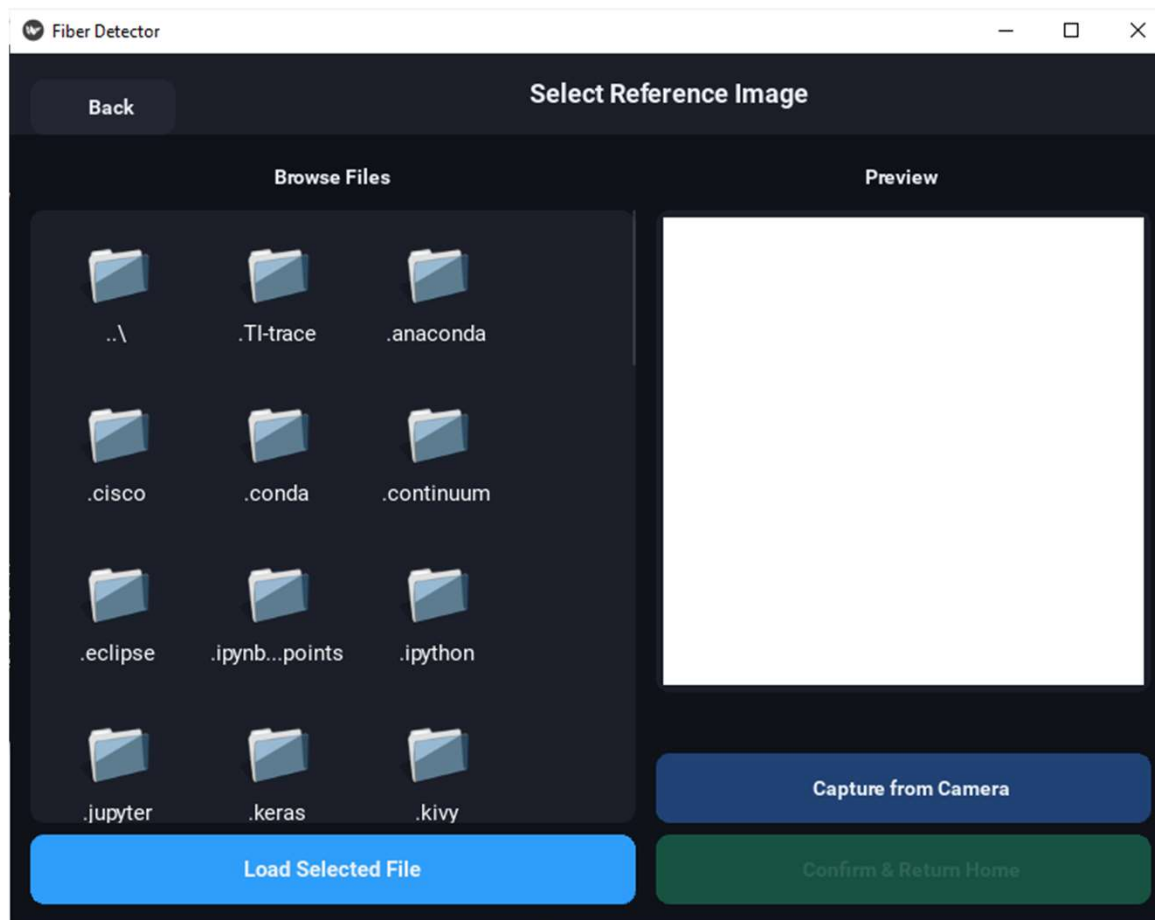

- Access to files
- Preview of potential reference image
- Option to either select reference from files or capture one with camera

# App Capture Screen UI

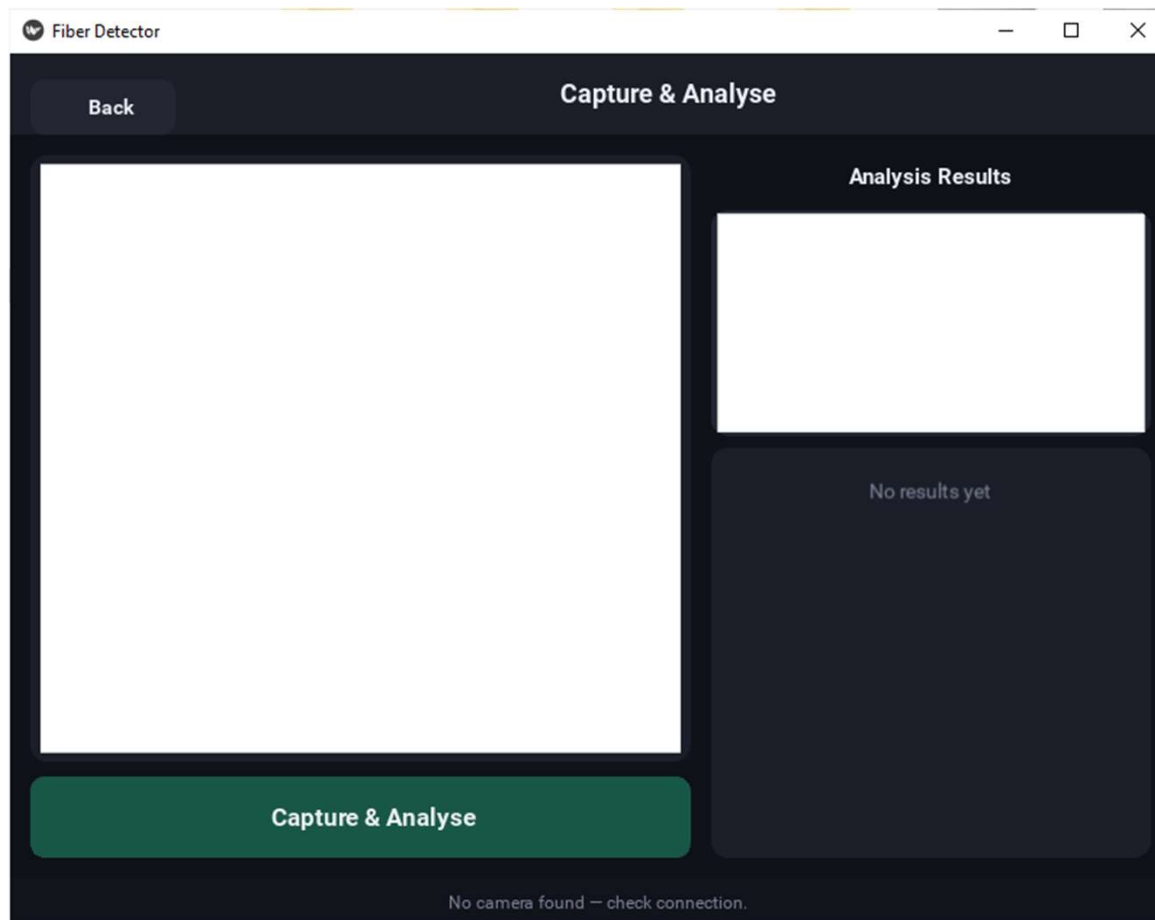

- Allows for preview of image
- Indicates camera connection
- Shows results and analysis

# App Previous Tests Screen UI

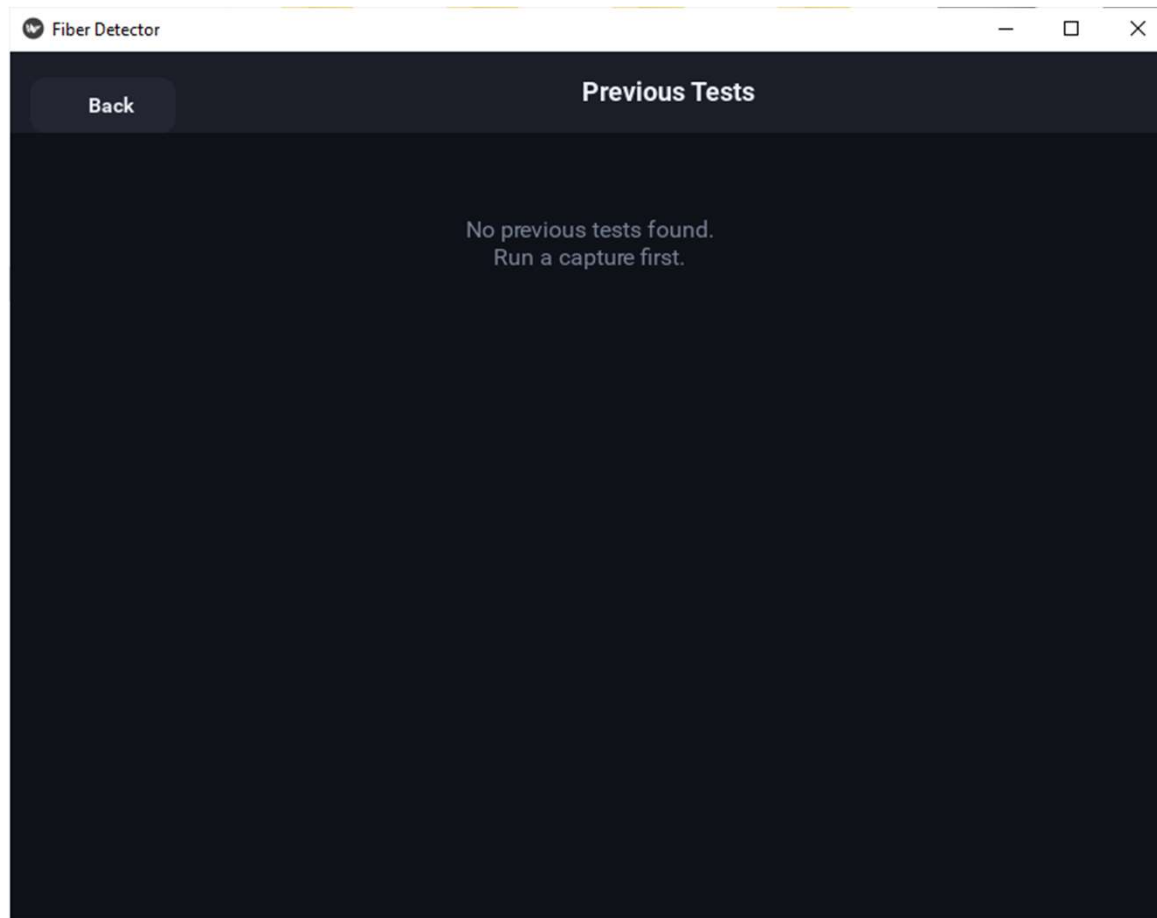

- Lists previous test
- Ease of access
- Provides results information

# Sequential Zemax Simulations



- Blue = Light
- Simulations used for:
  - Verify ray trace calculations
  - Optimize for low aberrations
- Tools used:
  - OPD fan plots
  - Ray spot diagram
  - Stray light analysis

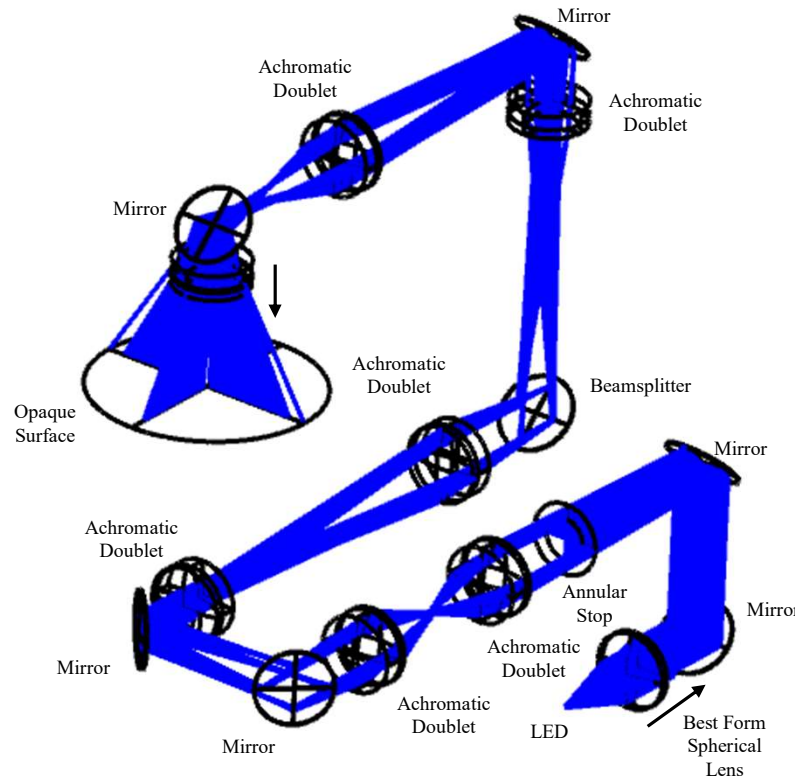

*Illumination Sub-System Simulation*

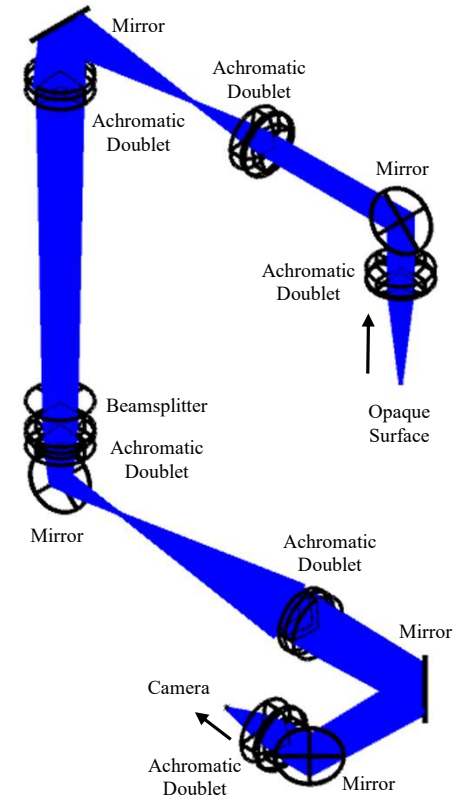

*Detection Sub-System Simulation*

\*We cannot share system design calculations and dimensions due to a non-disclosure agreement with ASML\*

# Non-Sequential Zemax Simulation



- Blue = Light
- Non-sequential enables scattered light analysis
- Integrated illumination and detection subsystems
- Simulations used for:
  - Scatter power
  - Further ghosting analysis

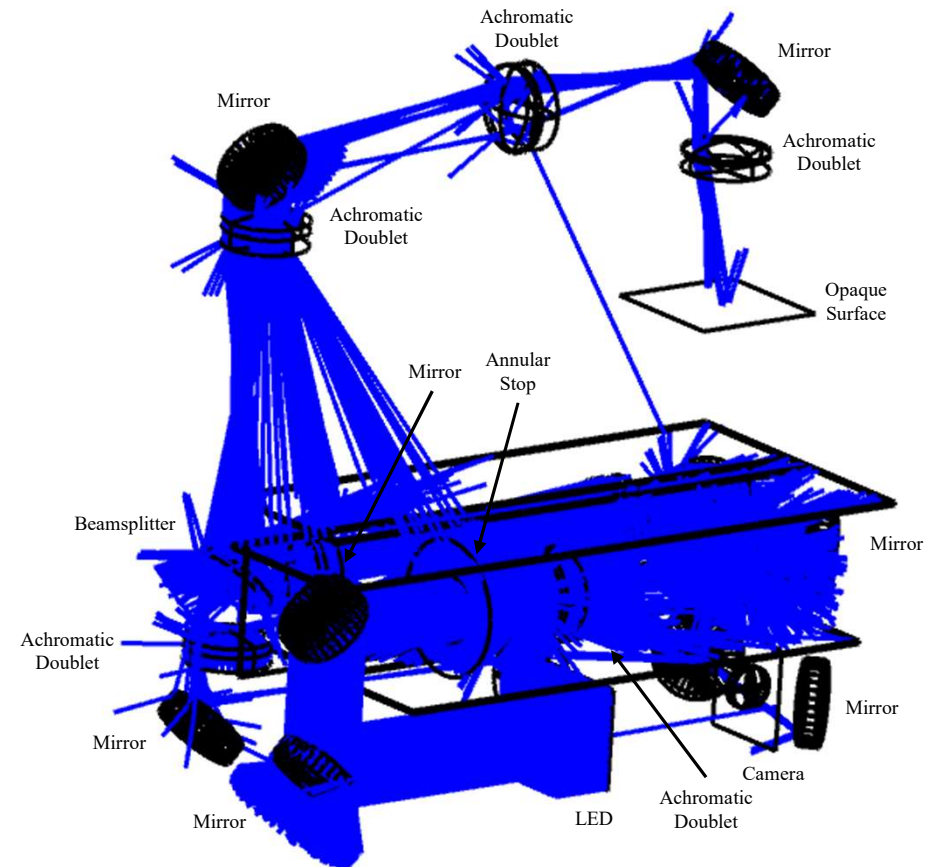

\*We cannot share system design calculations and dimensions due to a non-disclosure agreement with ASML\*

# Detection Testing

## Detection Optics

- Set up optical components for detection on optical rail
- Tested feasibility of proper alignment of components
- Expected magnification is within our target range
- Ran 10 tests and calculated average magnification as within our target range
- Proved our systems ability to image small particles and remain in focus.

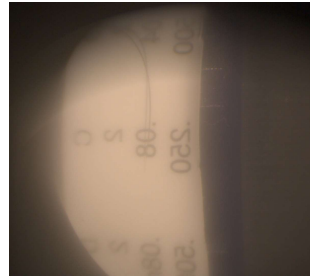

Text slide with hair on top without illumination

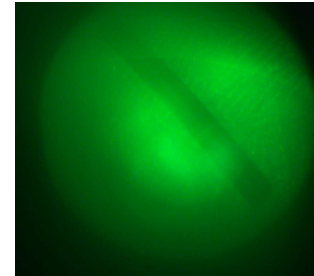

Aluminum surface with a small piece of wire rubber on top (note the fingerprint)



The surface of a key

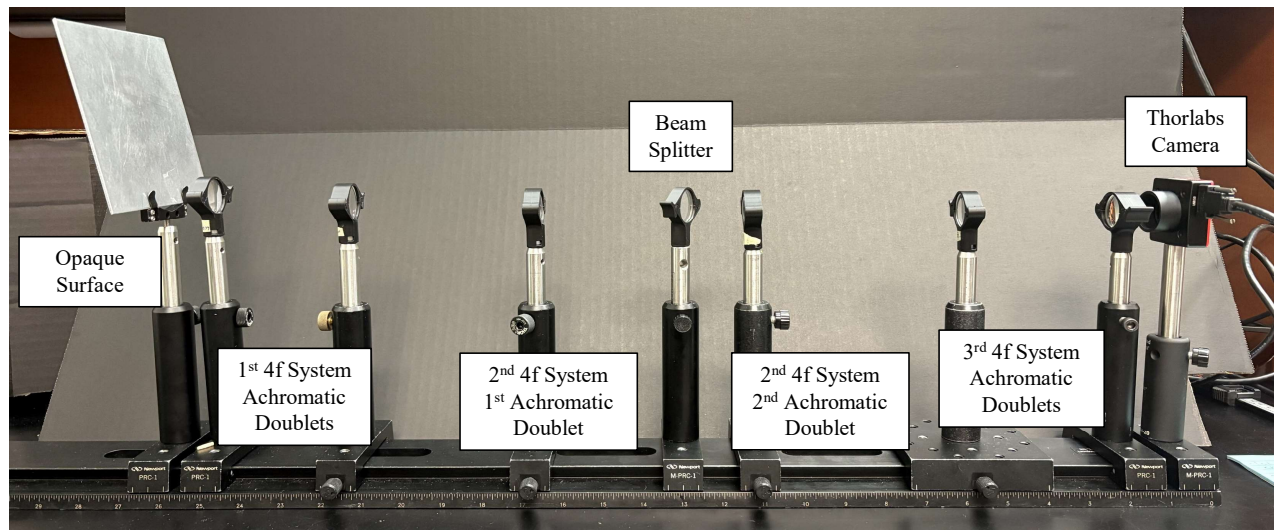

\*We cannot share system design calculations and dimensions due to a non-disclosure agreement with ASML\*

# Illumination Testing

## Annular Stop Size

- Set up illumination lenses on optical rail
- Tested 10 different annular stop inner radii and recorded spot diameter at opaque surface
- Smaller inner radius = Smaller detection half angle
- Smaller detection angle = Less edge scattering
- $\geq 11$  mm inner radius causes annular stop to miss lens working diameter due to LED divergence
- Chose 10 mm inner radius

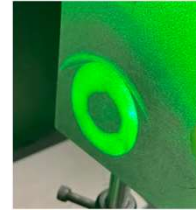

Annular mask before 1<sup>st</sup> lens of 2<sup>nd</sup> 4f system of the illumination sub-system

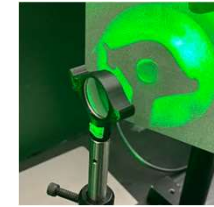

Annular mask after 1<sup>st</sup> lens of 2<sup>nd</sup> 4f system of the illumination sub-system

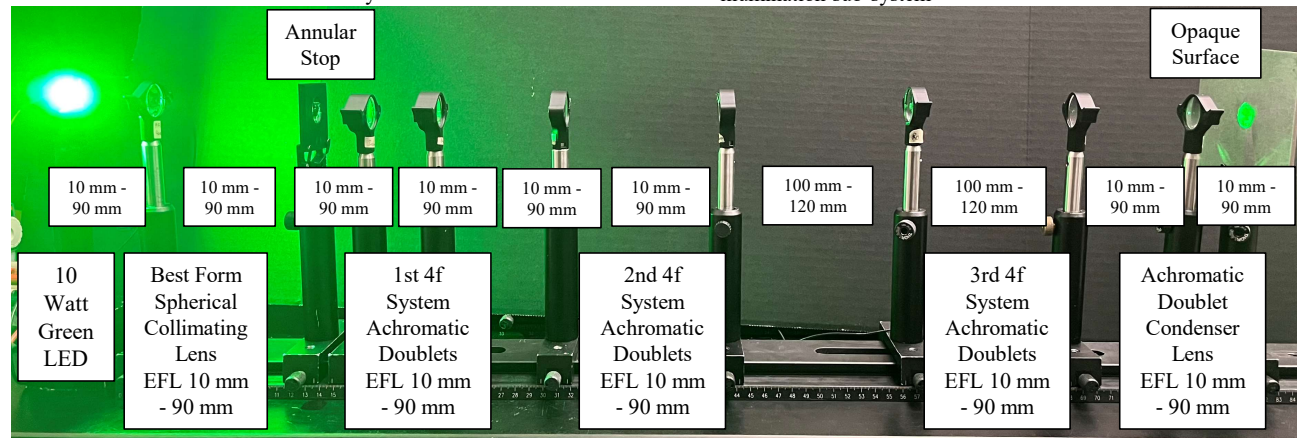

Detection Half - Angle vs Annular Stop - Inner Diameter

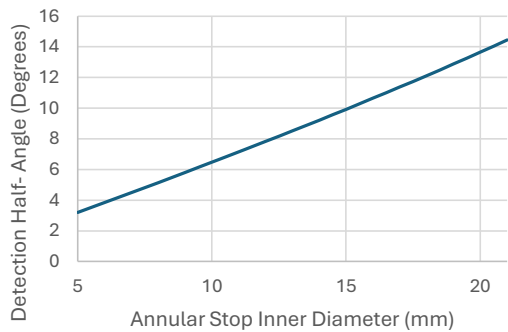

Annular Stop Inner-Diameter vs Illuminated Spot Size

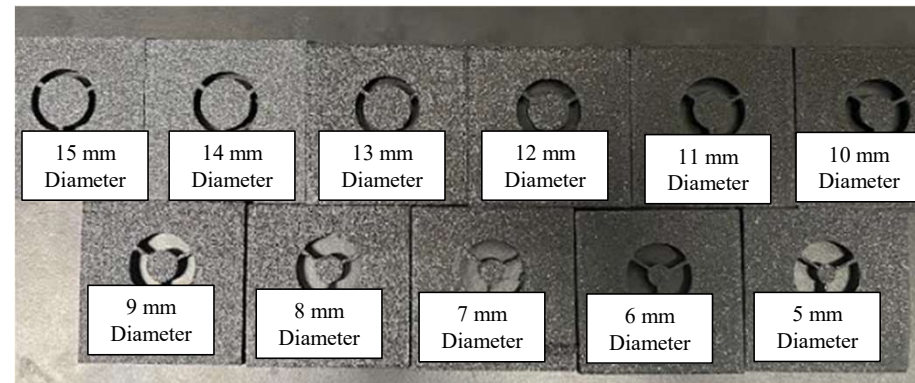
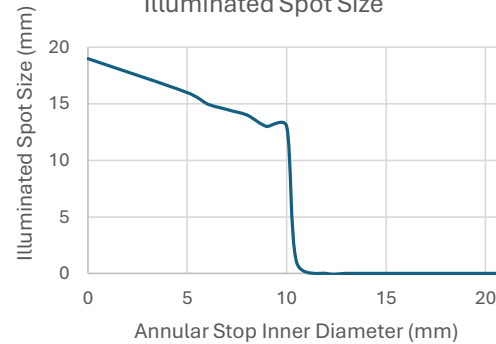

\*We cannot share system design calculations and dimensions due to a non-disclosure agreement with ASML\*

# Illumination Testing



## Power Efficiency

- Set up illumination optical components on optical rail
- Used power meter to detect optical power after each 4f system
- Measured power 3 times
- Average power efficiency = 2.7 %
- Average power at opaque surface average = 136  $\mu$ W
- Most power is lost from collimating lens
- Power efficiency of actual system is lower due to the 6 mirrors in the illumination sub system
- Challenging to test complete system efficiency with optical breadboards from undergraduate lab

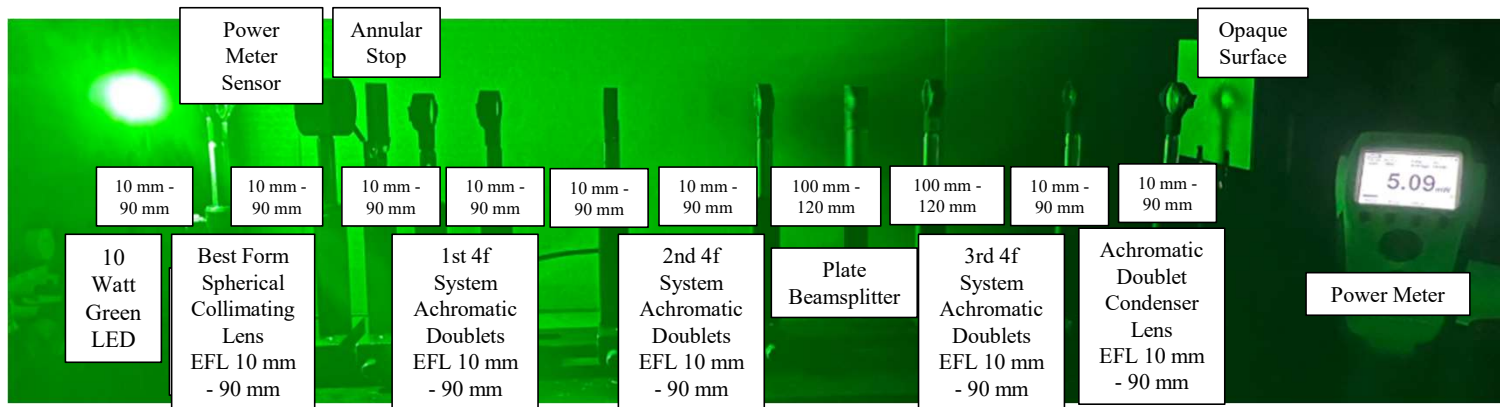
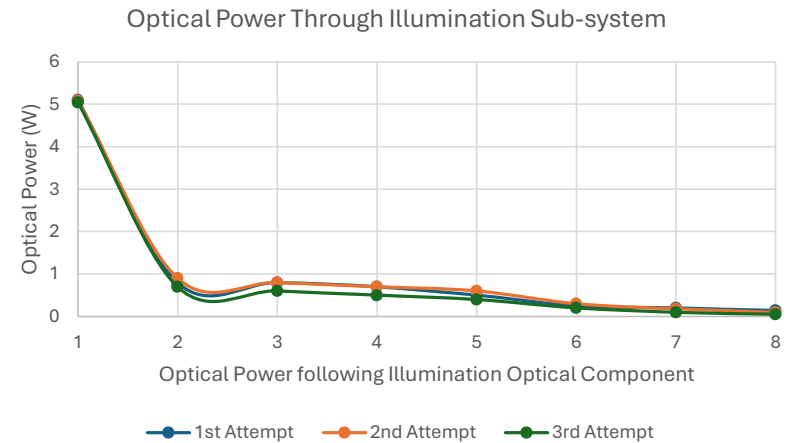

- 1 = LED
- 2 = Collimating Lens
- 3 = Annular Stop
- 4 = 1<sup>st</sup> 4f System
- 5 = 2<sup>nd</sup> 4f System
- 6 = Beamsplitter
- 7 = 3<sup>rd</sup> 4f System
- 8 = Condenser Lens / at Opaque Surface

\*We cannot share system design calculations and dimensions due to a non-disclosure agreement with ASML\*

# Algorithm Testing



1. Reference Image

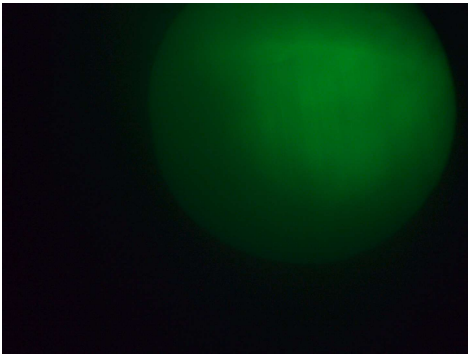

2. Contaminated Image

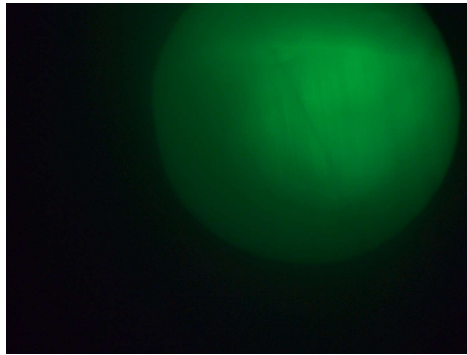

3. Binary Mask



4. Result



## Setup

- Testing for the algorithm had to be performed under full system condition to account for:
  - Picture quality
  - Magnification
  - Illumination & contrast
- Tests were performed by capturing a reference image, introducing a contaminant, capturing the image to be analyzed, and the running the algorithm.

## Testing

- For each run, we introduced different object of different sizes. However, we focused mostly on hair.
- On the left we can see the images for test run #4, including the reference, contaminated, the binary mask, and the result

# Algorithm Testing Results



Test Number	Contaminant(s)	Result
1	Paper clippings #1	Success
2	Hair #1	Success
3	Wire Clipping	Success
4	Hair #2	Success
5	Hair #3	Success
6	Hairs #4 & #5	Success
7	Dust	Success
8	Paper clippings #2	Success
9	Hair #6	Success
10	Hair #7	Success

## Results

- Results were positive, and each test case was able to be successfully resolved
- Adjustments to the code were required, however, for these parameters:
  - min\_threshold
  - min\_area
  - max\_area
  - blur\_ksize
  - Iterations of morph\_close

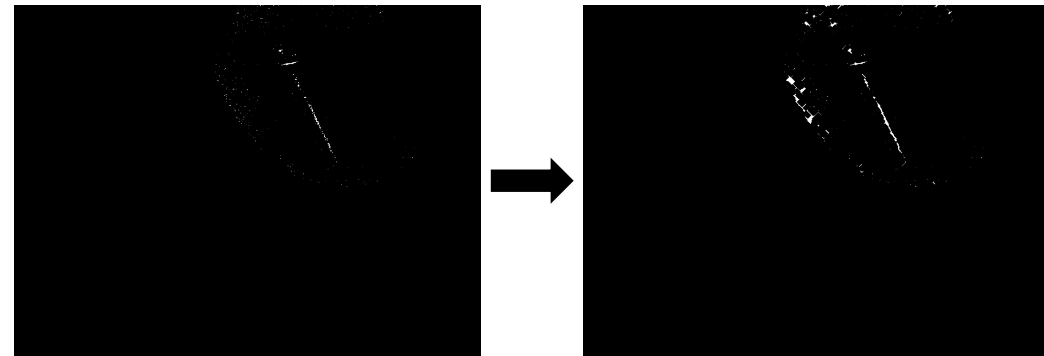

Test #4

Before & after adjusting: Iterations of morph\_close

# Component Power Testing



## Setup

- Testing for the power supply was conducted on the following components:
  - LED
  - LED Driver
  - Batteries
- LED Driver was tested using both a power supply and batteries.
- LED was tested using power supply and power supply + batteries



LED with batteries

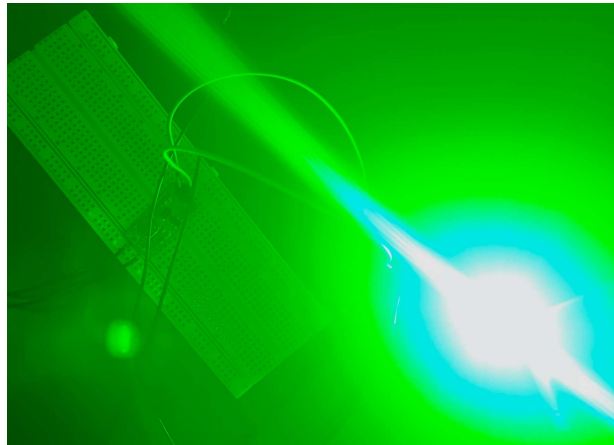

LED with power supply

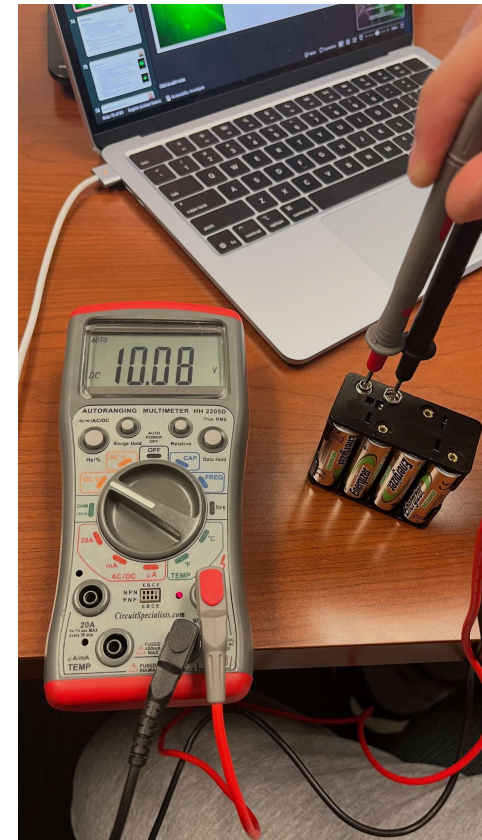

Battery voltage testing

# LED Control Testing



## Setup

- To test the LED control through the Arduino, we connected the driver, LED, and Arduino
- A script checking for basic controls was run, this included:
  - Basic on/off control
  - Blinking 3 times
  - Simulation of image capture timing

```
christian@PIDI:~/Downloads$ python3 arduino_led_test.py
[Info] Found ports: ['/dev/ttyACM0']
[Info] Auto-detected port: /dev/ttyACM0
[Info] Connecting to Arduino on /dev/ttyACM0 at 9600 baud...
[Info] Waiting 2s for Arduino to reset after connect...
[Info] Arduino ready.

— Test 1: Basic ON/OFF —
Sending LED_ON...
Sending LED_OFF...
Basic test done.

— Test 2: Blink 3 times —
Blink 1/3 - ON
Blink 1/3 - OFF
Blink 2/3 - ON
Blink 2/3 - OFF
Blink 3/3 - ON
Blink 3/3 - OFF
Blink test done.

— Test 3: Simulate capture sequence (ON → 1s → OFF) —
LED ON - simulating illumination warmup...
Capturing frame... (simulated)
LED OFF - capture complete.
Capture simulation done.

[Info] Serial port closed. All tests passed.
```

# Challenges



## Administrative

- Original mentor from ASML quit without notifying us
- Coordinating a new mentor set timeline behind by about 2 months
- Received electrical components 2.5 months after sending the bill of materials to sponsor
  - This set algorithm testing behind schedule
- Sponsor sent wrong components when the project was already behind schedule
  - We received 10 beamsplitters and 1 mirror instead of 1 beamsplitter and 10 mirrors
  - This set integration of illumination and detection subsystems behind schedule
  - This affected testing algorithm integration with full system

## Electrical

- Off-the-shelf requirements
  - Not being able to design PCB made integration more challenging
- Dimension constraints
  - Due to the dimensions, no heatsink is attached to the LED, making it unable to operate for extended periods of time
- High Powered LED added power consumption challenges

# Challenges

## Optical

- Dimensional constraints with off-the shelf components requirements from sponsor made a complete dark-field image not feasible
  - Annular stop size given our constraints must get demagnified from the free space requirement
  - To achieve dark-field image, annular stop need to be 21 mm in diameter before the condenser lens
  - If we try to magnify then demagnify the annular stop, it misses lenses' working diameter since we are limited to 1 inch optics from dimensional constraints
  - Our project still enhances edge scatter but does not result in a complete dark-field image
- Collimating lens diverges illumination beam more than expected
  - Limited on time after receiving components so we could not buy an alternative collimating lens
  - Causes the mask of the annular stop to miss working diameter of the 1st lens in the 2nd 4f system in the illumination subsystem
  - Tested different inner radius dimension of the annular stop to see at what size the annular stop does not miss lenses' working diameter
  - This causes less edge scattering lowering the dark-field effect on the image
- LED chosen is composed of nine LEDs in a grid
  - Caused inconsistency of intensity in the illumination beam on the opaque surface
  - Added a diffuser in front of the LED to make the nine-point sources homogeneous
- Finding Zemax recourses since our sponsor requested non-sequential simulations (no prior experience in non sequential mode)
  - Imaging professor resigned so had to coordinate with the CREOL Dean for other faculty members with prior non-sequential Zemax experience
  - Got connected with Dr. Grimming, who helped guide us through the non-sequential Zemax simulation

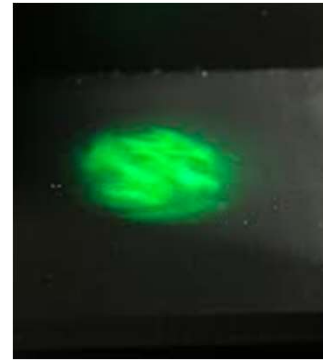

Illumination beam at opaque surface before adding a diffuser:

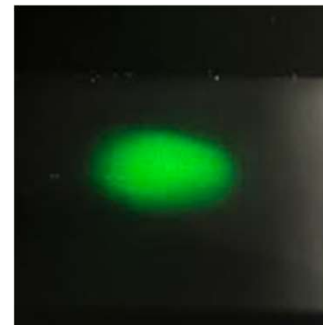

Illumination beam at opaque surface after adding a diffuser:

# Future Improvements



- Use custom optics to provide a dark-field image in the given dimensional constraints
- Enlarge the housing and reduce free space dimensions to allow for better integration of illumination and detection subsystems
- Chose a collimating lens with lower beam divergence which will allow the use of larger annular stop
- Chose a single point source LED to avoid using a diffuser
- Add a heatsink to the LED to fix heating
- Machine Learning model could replace the algorithm given more time



# **Administrative Content**

# Work Distribution



Task	Primary	Secondary
Darkfield Illumination	Kirolos	Julian
Illumination Lenses Design	Kirolos	Julian
Image Detection	Julian	Kirolos
Detection Lenses Design	Julian	Kirolos
Magnification	Julian	Kirolos
Housing Design	Ryan	All
CAD of System	Ryan	-
Manufacturing	Ryan	All
Touch Screen	Christian	-
Detection Algorithm	Christian	-

# Bill of Materials



Component	Part Name/Number	Quantity	Unit Price	Total Price
<b>Optical Engineer</b>				
Camera (1.6 MP CMOS)	CS165CU	1	\$513.45	\$513.45
Illumination Source (10 W Green LED)	1DGL-JC-10W-GR	1	\$6.99	\$6.99
Pellicle Beam Splitter	BP145B1	1	\$224.99	\$122.03
Dielectric Flat Mirrors	BB1-E02	10	\$86.91	\$869.10
Collimating Lens	LBF254-040-A	1	\$54.67	\$54.67
Achromatic Doublets	AC254-0XX-A	10	\$95.34 - \$102.96	\$976.26
<b>Computer Engineer</b>				
LattePanda Mu Intel N100 x86 Compute Module Kit	B0D4VC43HC	1	\$209.00	\$209.00
Belker 45W Universal AC DC Adapter Power Supply	PA-30450H-ZMX	1	\$16.90	\$16.90
Waveshare 7" Display	779172278936	1	\$46.59	\$46.59
Amazon Basics 8-Pack Rechargeable AA NiMH Batteries	HR-3UTG-AMZN (8P)	1	\$12.80	\$12.80
LD24AJTA Constant Current LED Driver	Fayelume91f7im5gc2	1	\$12.99	\$12.99
QTEATAK 2Set 8 x AA Thicken Battery Holder	SY-G03B-BGI7	1	\$8.99	\$8.99
Arduino Nano ESP32	ABX00083	1	\$19.30	\$19.30
<b>Mechanical Engineer</b>				
Steel Flat Head Thread forming screws 10mm	90434A126	100	.1886	\$14.86
Steel Flat Head Thread forming screws 16mm	90434A151	100	.1161	\$11.61
Black PLA -CF filament 1kg	3502N211	2	47.27	\$94.54
Black PLA 1 filament .5kg	1317n22	4	34.60	\$138.40
Matt duct tape	7612A25	1	16.76	\$16.76
<b>Total Cost</b>				
Optical Components			\$2,542.50	
Electrical Components			\$326.57	
Mechanical Components			\$276.17	
Grand Total			\$3,145.24	

# Thank You!

*Dr. Chung Yong Chan*

*Dr. Aravinda Kar*

*Dr. Kyu Young Han*

*Dr. Azadeh Vosoughi*

*Dr. Hadi Mardani Kamali*

*Dr. Sagnik Mazumdar*

*Dr. Navneet Dhindsa*

*Dr. Lirong Wang*

*Dr. Akram Raub*

*Dr. Kimi Huang*

*Dr. Andres Guevara*