

# Optical Chlorine Concentration Analyzer

Jackie Zhao, Franley Casado, Giovanni Maldonado-Velez

University of Central Florida School of Electrical Engineering and Computer Science, College of Optics and Photonics, Orlando, FL

**Abstract** — The Optical Chlorine Concentration Analyzer (OCCA) is inspired from water treatment plants which go through a variety of processes to ensure the water that we drink is pure and safe for consumption. This project focuses on analyzing chlorine concentration in water, which is often used in water treatment plants to purify the water of microorganisms at the cost of altering the water's taste and, at higher concentrations, possibly making the water unsafe to drink. The original vision for this project was to both analyze chlorine concentrations in a water sample of at least 10mL and then dechlorinate it, with both functions involving optics. However, the integral group member who was going to develop the dechlorination aspect withdrew from the project in the second half of our development and as such we needed to reduce the scale.

**Index Terms** — Chlorine Concentration, DPD Reagent, Optics, Water Analysis.

## I. INTRODUCTION

Water treatment is a multi-step process which takes account of a variety of contaminants that could be present within water. The two primary types are biological (in the form of microorganisms such as bacteria) and chemical (such as lead) [1]. In order to disinfect the water and kill microorganisms, chemicals such as chlorine are introduced and then filtered out of the water [2]. Since chlorine is a widely used method of water disinfecting, the methods to get a reading on its concentration are numerous and can be as small as a strip that reacts to its presence [3], to as large as a sophisticated device which accurately reads out the value in parts-per-million (ppm) present in a water sample [4]. The Optical Chlorine Concentration Analyzer is designed to compete with the latter option while finding a balance between cost and performance. The OCCA is intended to work as follows: one takes a chlorine sample from a water source using a testing tube, adds a reagent known as *N,N*-diethyl-*p*-phenylenediamine (DPD for short) [5] to the sample, shake the sample well to distribute the reagent until the pink color is present, place the sample into the

designated spot within our system, and then the OCCA will give its user the detected chlorine concentration via an application developed for the project in a timely manner.

## II. SYSTEM COMPONENTS

This section introduces the major system components and their purpose briefly, as well as the part we purchased to create our system. A more in-depth view on each of the components is present in section 4, titled “*Hardware Details.*”

### A. Microcontroller

The microcontroller selected for the project is the Arduino Uno WiFi Rev2. The board was chosen for its simplicity, extensive documentation, and built-in WiFi connectivity. The board uses the ATmega4809 8-bit microcontroller that can run up to 20MHz with Flash sizes up to 48KB, 6KB of SRAM, and 256 bytes of EEPROM. The board's code will be written in a variant of C++ in the Arduino IDE, the Arduino IDE provides a C++ code editor, a program upload utility, and a GNU C++ compiler.

### B. GPS Shield

A GPS shield is used to track the location of the system. The shield selected is the Adafruit Ultimate GPS Logger Shield, this shield is designed to be placed on top of an Arduino Uno R2 and uses the MTK3333 chipset. The GPS Shield has a -165 dBm sensitivity, 10 Hz updates, 99 channels, and a low 30 mA current draw. Longitude and Latitude data will be logged and sent to the mobile app through UDP communication.

### C. Speaker

The audio alarm system will primarily rely on passive piezo speakers, chosen over active piezo speakers for their ability to customize tone, frequency, and volume. Unlike active piezo speakers, which have a built-in oscillator and produce a fixed sound, passive piezo speakers require an external signal to generate sound. This allows for greater flexibility in tailoring the audio output to meet specific needs. By using a passive piezo speaker, the system can be programmed to emit a unique sound that can vary in pitch and volume, ensuring the alarm is distinct and easily recognizable. This customization enhances the effectiveness of the alert system, making it more noticeable and thereby increasing the likelihood of a quick response to hazardous chlorine levels.

### D. Laser

For this system, we chose the Apinex BES532, which has a wavelength of 520 nm and a power of 5mW. The laser's role in the system is to go through a beam splitter,

which then splits the laser down two paths that both end in a photodiode: one with the chlorine sample and one without. The path without the chlorine sample will not be attenuated and as such will act as our baseline, while the path with the chlorine sample will absorb some of our laser and cause a weaker signal to reach the photodiode at the end of its path. By comparing the loss in current reading across both photodiodes, we can calibrate the system to be able to accurately interpret the detected chlorine in any water sample into a known ppm value, which then informs the user on what to do next with the water source.

### E. Photodiode

Photodiodes play a crucial role in our system by converting the optical power emitted from the laser into a current our board can read. The specific photodiode selected for our system is the Vishay BPW21R due to its sensitivity to our laser’s wavelength of 520 nm. Our system uses two of them and both lie at the end of the paths mentioned in section D, which talks about our laser, as well as figure 1, which is our hardware block diagram.

### F. Server

The server selected for our project was Amazon Web Services (AWS) for its extensive range of features, scalability, and reliability. AWS supports User Datagram Protocol (UDP) communication, which is crucial for our project. This compatibility ensures seamless data transmission from the Arduino to the server, facilitating real-time logging and monitoring of location and chlorine concentration data.

### G. Development Platform

The development platform selected for the creation of the mobile application was Flutter. Flutter is an open-source UI software development that allows for the creation of natively compiled applications for mobile, web, and desktop from a single codebase. It enables the development of applications that work seamlessly on both Android and iOS platforms reducing development time. Its high performance ensures that the application runs smoothly and efficiently. Flutter ability to integrate with existing code, libraries and Application Programming Interface (API) is versatile for our project.

### H. DPD (*N, N*-diethyl-*p*-phenylenediamine)

The inclusion of DPD reagent in the project is integral for precise chlorine level determination in water samples. DPD reagents react specifically with free chlorine species, producing a colorimetric response—typically pink or red—that correlates directly with chlorine concentration. This reaction enhances the optical absorption properties of

the water sample, which enables us to select an easier-to-attain laser diode for our system, as well as make chlorine detectable within the water sample.

## III. SYSTEM CONCEPT

A hardware block diagram and software block diagram is shown to provide a better understanding of the entire system and distributed workload.

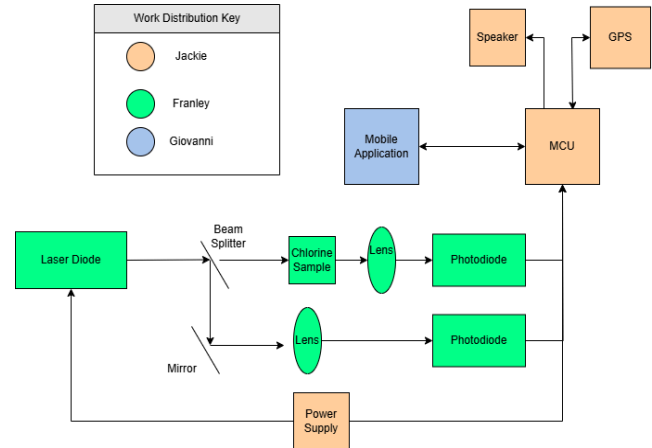

Fig. 1. A hardware block diagram that shows the flow of data, connections, and communication.

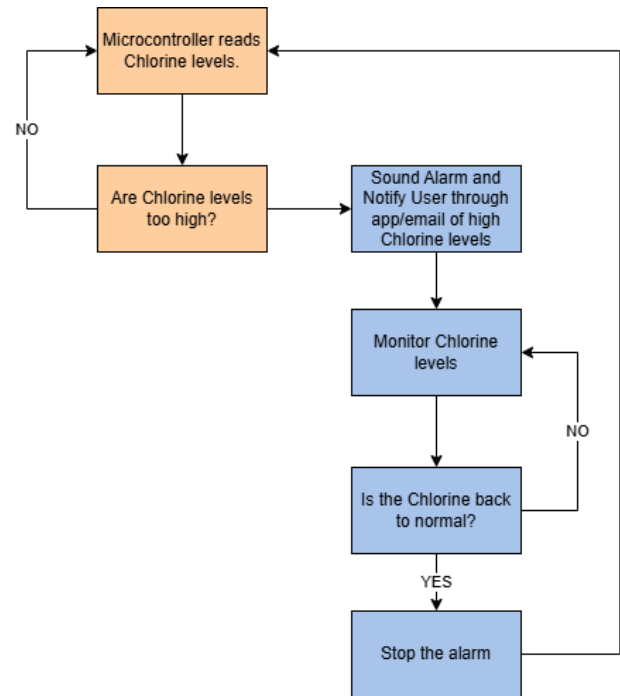

Fig. 2. A flowchart of the electrical and software system showing the flow Chlorine data and what is done at certain thresholds with a distributed workload.

There are two states that our system follows: monitor and alarm state. The monitor state serves as the default operational mode, where the system is actively engaged in tracking the optical power from the laser using photodiodes. In this state, the photodiodes continuously measure the intensity of the laser beam passing through the water sample. The Arduino WiFi Rev2 microcontroller reads these measurements as analog voltage values through its analog input pins. These readings are crucial as they correspond directly to the chlorine concentration levels in the water. The processed data is then transmitted to a mobile application using UDP communication, allowing for real-time monitoring. This ensures that any variations in chlorine concentration are promptly recorded and made available for analysis.

Additionally, the system incorporates a GPS module, which parses the longitude and latitude data of the system's location. This geolocation information is sent to a server, and by utilizing Google APIs, we can derive an approximate address for the system's location. This feature is particularly useful for tracking and managing multiple systems deployed in different areas. In the monitor state, there is no alarm triggered, as the chlorine concentration levels are within safe limits, posing no danger for skin contact. This state ensures continuous and precise monitoring, providing a steady flow of data without causing unnecessary alarms.

The system transitions to the alarm state when the chlorine concentration exceeds the pre-established safety threshold. This state is critical for alerting users to potentially dangerous conditions. The alarm system is composed of a passive piezo speaker, the Arduino microcontroller, and a GPS shield. Upon detecting chlorine levels above the safe threshold, the alarm state is activated. The passive piezo speaker emits a loud audible alarm to alert nearby individuals of the hazardous condition. This immediate auditory warning is essential for quick local response.

Simultaneously, the GPS shield provides updated location information, which the Arduino reads and transmits to the backend server. The server processes this data and triggers alert messages to be sent to the mobile application. The user receives notifications through push alerts on their phone, ensuring they are promptly informed about the high chlorine levels. Additionally, a corresponding email is sent as a backup measure, providing an extra layer of notification. This dual notification system guarantees that the user is aware of the dangerous situation, regardless of their current device usage. The alarm state enhances the safety and responsiveness of the overall system by ensuring timely

and effective communication of potential hazards, allowing for immediate action to mitigate risks.

Furthermore, all information gathered by the system, including photodiode readings and GPS data, is readily available to the user through the mobile application. This comprehensive access allows users to monitor chlorine levels in real-time, view historical data, and track the precise location of each monitoring system. The application provides a user-friendly interface where users can see the current chlorine concentration, receive status updates, and review past readings to identify trends or anomalies. By integrating both photodiode measurements and geolocation data, the mobile app ensures that users have a complete and detailed view of their water quality monitoring system, enabling them to make informed decisions and respond swiftly to any potential issues. This level of accessibility and transparency enhances user confidence and control over their water safety management.

#### IV. HARDWARE DETAILS

In this section, the hardware components of the project will be discussed in further detail. Some components covered in Section II are omitted for sake of redundancy. The PCB is omitted and given its own section.

##### A. Laser and DPD

The laser selected for the OCCA was the result of speaking with engineers who work for and collaborate with Rodem [2], a company which sanitizes water across the USA for a variety of different purposes, as well as a study which gave us the exact wavelength DPD absorbs to ensure we can detect chlorine concentrations in water. The initial problem that arises when attempting to analyze the chlorine concentration by using laser attenuation is that chlorine responds to laser wavelengths from 280 nm to 350 nm [6]. These wavelengths lie outside of the visible spectrum (400 nm to 700 nm) and as such are both costly and difficult to properly align due to lasers outside of the visible spectrum being invisible to the naked eye. This is where the DPD described in the introduction of our project presents its value. When added to water which contains chlorine, DPD reacts with it to create a pink color which has a distinct absorption spectrum, denoted by figure 3.

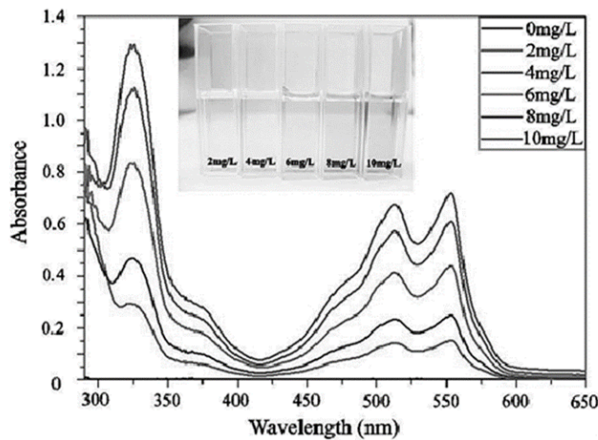
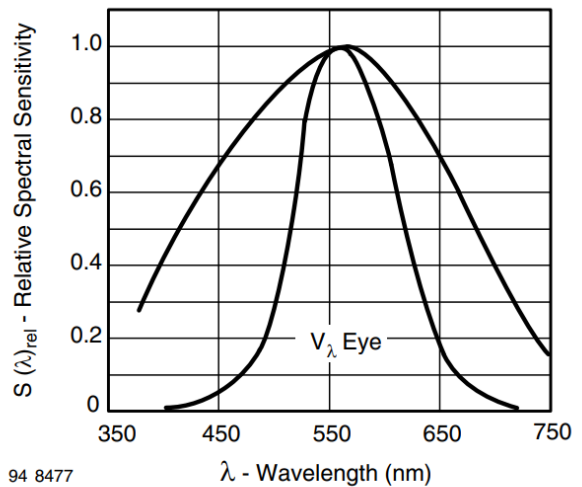

**Fig. 3.** Absorption spectrum of DPD upon reacting with water. Note peaks outside of visible range (400 nm to 700 nm) and new peaks in visible range (520 nm and 550 nm approximately). [6]

Figure 3 has two distinct peaks in the visible spectrum: at 520 nm and 550 nm, approximately. Upon comparing options across the market, we opted to select a laser at 520 nm due to more options being present at this wavelength. We opted for 5 mW of power as it was powerful enough to make the light budget much easier to manage while remaining mostly safe for the eyes, assuming it isn't shined directly into the retinas. This led us to selecting the Apinex BES532 [7], a green laser module which fulfills all the aforementioned requirements. Within our system, the laser diode is shined through a beam splitter which then splits the laser into two paths: one with the water sample and one without. At the end of both paths lie identical photodiodes, which have differing values based on how much the laser is attenuated through the water sample path, which is then interpreted by the Arduino to an approximate chlorine concentration. The aforementioned optical paths are explicitly shown in figure 1.

### B. Photodiode

The Vishay BPW21R [8] was selected after our laser diode was finalized. Its responsivity to 520 nm, as denoted in the figure below, is one of the primary selling points that made our group select it. Besides that, the photodiode also sports a somewhat large active area of 7.5mm<sup>2</sup>, which gives our system more room for error as mild misalignments in the laser diode won't affect current readings too heavily in our system.



**Fig. 4.** Relative Spectral Sensitivity vs Wavelength of Vishay BPW21R, taken from the component's data sheet. Note the sharp response to its center wavelength of 550 nm, with 100% responsivity. At 520 nm, the responsivity is about 93%, which is acceptable for our purposes. [8]

Once the photodiode type was selected and tested to ensure its compatibility with our laser diode, the next step for our photodiodes was to integrate them into our PCB, which is noted in detail in section 5, *PCB Details*.

### C. LF351N Operational Amplifier

We selected the LF351N operational amplifier for its performance characteristics that align perfectly with our system's requirements. Known for its low offset voltage, low drift over temperature, and high input impedance, the LF351N ensures accurate signal amplification from our photodiode, critical for precise light intensity measurements. Its wide bandwidth and high slew rate enable fast response times, crucial for real-time data processing in our application. Additionally, the LF351N's robust design and compatibility with our power requirements make it an ideal choice, providing reliability and stability essential for long-term operation in our monitoring system.

### D. Power Supply

The project utilizes a 9V 1A DC 100V-240V wall plug as its main power supply, which is compatible with the Arduino and provides adequate power for all other system components. This power supply is used to supply positive voltage to the project's overall setup. However, the photodiode system includes an operational amplifier (op-amp) that necessitates a negative voltage supply. To meet this requirement, a 9V battery and a 9V battery pack

holder are employed to provide the necessary negative voltage. The choice of 9V for both the positive and negative voltage supplies ensures consistency in power delivery throughout the system, facilitating reliable operation and ease of maintenance.

### V. PCB DETAILS

Our system is divided into two Printed Circuit Boards (PCBs). The main board houses the Arduino Uno Rev2, GPS shield, and piezo speaker. The second board, the photodiode board, contains the photodiode and LF351N operational amplifier.

The main board functions as the control center of the system. The Arduino serves as the power source, supplying power to the photodiode board and the GPS shield. It also controls the logic for activating the piezo speaker and the laser. Vias on the main board facilitate connections from the photodiode board, enabling the Arduino to receive its readings.

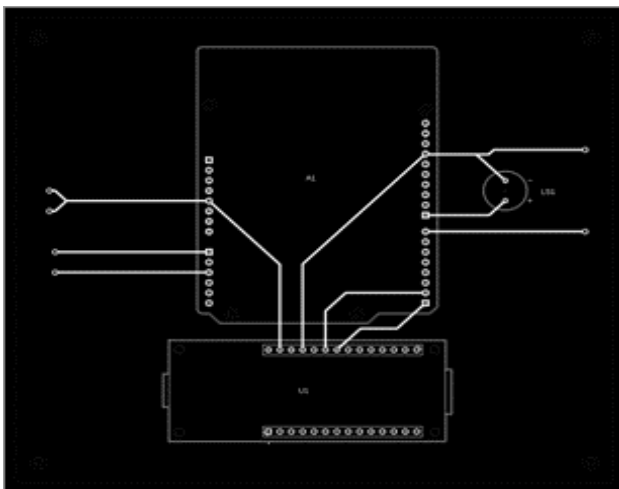

Fig 5. Main Board Schematic.

The photodiode board houses a photodiode, a 100nF capacitor, a 100k resistor, an LF351N operational amplifier, and four pin headers for powering the operational amplifier. These components work together to enhance the photodiode's performance as follows: the photodiode detects light intensity and converts it into an electrical current, 100K Resistor converts the current generated by the photodiode into a measurable voltage, LF351N operational amplifier amplifies the small voltage signal from the photodiode, making it strong enough for the Arduino to process accurately. It also maintains a linear relationship between the light intensity and the output voltage, 100nF Capacitor filters noise from the power supply, ensuring a stable and clean signal, Four pin

headers provide the necessary power connections for the operational amplifier.

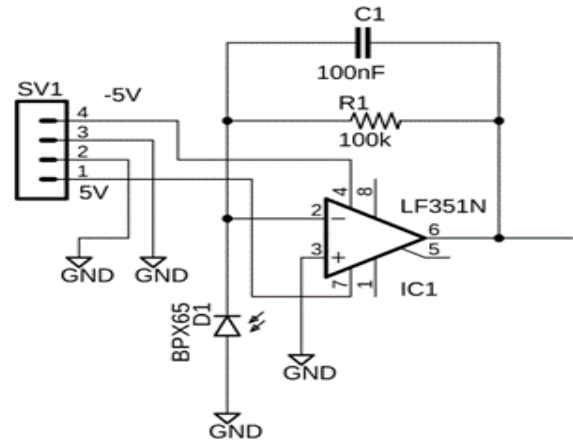

Fig 6. Photodiode Board.

### VI. SOFTWARE DETAILS

The mobile application features four main pages: Login page, Sign Up page, Landing page, and Profile page:

In the Login Page, users enter their credentials to access the application. This page includes buttons to navigate to the Sign Up page for account creation and a "Forgot Password" option. The "Forgot Password" function allows users to reset their password by entering their email address and receiving a code via email to authorize the reset.

In the Sign Up Page, users fill in their information to create a new account. After account creation, users are prompted to enter a verification code sent to their provided email address to verify it for notifications and secure usage of the application.

On the Landing Page, users can view the system's location, monitor the chlorine concentration in the water, and control the reading process with a start/stop button. When the reading process is active, the page provides real-time updates of the chlorine concentration received from the Arduino. The concentration levels are color-coded: red for high concentration, yellow for moderate concentration, and green for low concentration. Starting or stopping the reading process triggers an email notification to the user, informing them that the process has begun or ended and providing the final recorded value.

From the Landing Page, users can navigate to the Profile Page. Here, they can update their personal information or delete their account.

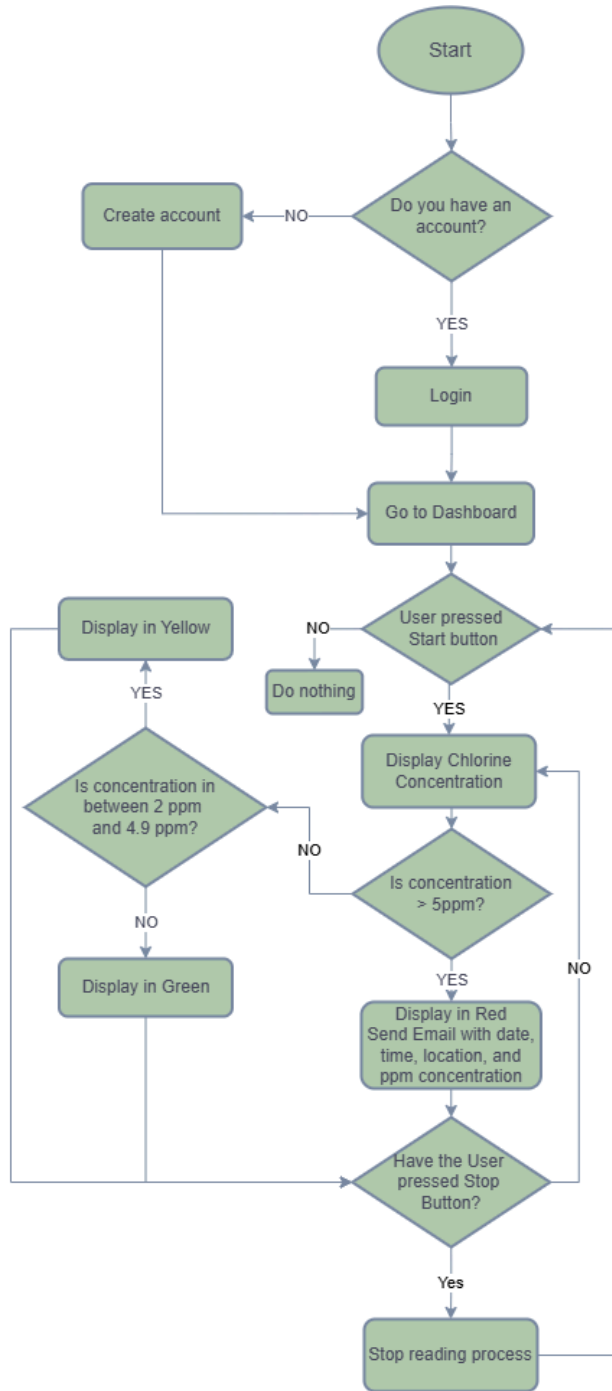

Fig 7. Mobile App Flowchart

THE ENGINEERS



**Jackie Zhao** is a 24 year old Computer Engineering student. He is currently working part-time for a company and plans to transition to full-time after graduating.



**Franley Casado** is a 22 year old Photonics Science Engineering student. He aspires to work in military applications with either a defense contractor or the US government in any branch.



**Giovanni Maldonado-Velez** is a 26 year old Computer Engineering student. He aspires to work in a company where he can apply the knowledge gained from electrical and software courses.

ACKNOWLEDGEMENT

The authors wish to acknowledge the assistance and support of Dr. Arthur Weeks, as well as Brian Gorchowski from Rodem and our project mentors, Dr. Aravinda Kar and Dr. Chung-yong Chan.

REFERENCES

[1] US Environmental Agency. *Environments and Contaminants Drinking Water Contaminants*. Oct. 2015, [www.epa.gov/sites/default/files/2015-10/documents/ce3\\_drinking\\_water.pdf](http://www.epa.gov/sites/default/files/2015-10/documents/ce3_drinking_water.pdf).

[2] Gorchowski, Brian. Rodem interview about UV Disinfecting. Conducted by Franley Casado. March 19, 2024

- [3] “Free & Total Chlorine Test Strips, 0-10 Mg/L.” *Hach.com*, 2024, [www.hach.com/p-free-total-chlorine-test-strips-0-10-mgl/2745050](http://www.hach.com/p-free-total-chlorine-test-strips-0-10-mgl/2745050). Accessed 5 July 2024.
- [4] “CL17sc Colorimetric Chlorine Analyzer with Standpipe Installation Kit and Reagents for Free Chlorine.” *Hach.com*, 2024, [www.hach.com/p-cl17sc-colorimetric-chlorine-analyzers/8572700](http://www.hach.com/p-cl17sc-colorimetric-chlorine-analyzers/8572700). Accessed 5 July 2024.
- [5] Halma PLC HLMA. “Measuring Chlorine Using DPD.” *Palintest.com*, [www.palintest.com/content-hub/measuring-chlorine-using-dpd/#:~:text=DPD%20stands%20for%20N%2CN](http://www.palintest.com/content-hub/measuring-chlorine-using-dpd/#:~:text=DPD%20stands%20for%20N%2CN).
- [6] Real-Time Detection of Residual Free Chlorine and pH in Water Using a Microchannel Device - Scientific Figure on ResearchGate. Available from: [https://www.researchgate.net/figure/Spectrum-analysis-of-DPD-reagent-solution-mixture-with-free-chlorine-sample-solution\\_fig3\\_227944260](https://www.researchgate.net/figure/Spectrum-analysis-of-DPD-reagent-solution-mixture-with-free-chlorine-sample-solution_fig3_227944260) [accessed 6 Jul, 2024]
- [7] “Green Laser Module.” *Www.apinex.com*, [www.apinex.com/ret2/BES532.html](http://www.apinex.com/ret2/BES532.html). Accessed 6 July 2024.
- [8] Vishay. *BPW21R Silicon Photodiode*. 23 Nov. 2011, [www.vishay.com/docs/81519/bpw21r.pdf](http://www.vishay.com/docs/81519/bpw21r.pdf).