

D-MILE

Distance-Monitored Inkless Laser Engraver

ECE Group 4:



Ethan Teodosio (PSE)

Franklin Ivey (CPE)

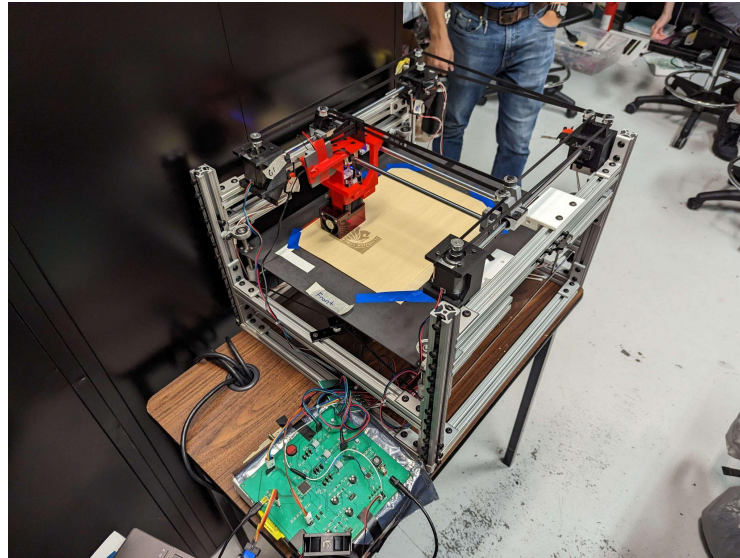

Ifran Tello (EE)

Sean McCormack (PSE)





Goals

Core Goals:

C1.0: D-MILE is safe to use and operate in a consumer environment.

C2.0: D-MILE has a high ease of use.

C3.0: D-MILE is economical.

C4.0: D-MILE has a high level of optical precision.

C5.0: D-MILE has a high level of motor control precision.

C6.0: D-MILE has an optical subsystem improving functionality.

Stretch Goals:

S1.0: D-MILE has an industry standard level of motor control.

S2.0: D-MILE has fully automated adaptability in x, y, and z.

S3.0: Switching between media or the thickness of media without manual adjustment needed.

Advanced

Goals:

A1.0: D-MILE is capable of multi-media printing.

A2.0: D-MILE has multiple optical subsystems expanding functionality.

A3.0: D-MILE is capable of printing gradients onto more resilient media such as wood.

A4.0: D-MILE has an improved level of motor control precision.

A5.0: D-MILE has manual control over the z direction.

A6.0: D-MILE will have an improved level of precision.



Objectives

(C1.0) To achieve our primary objective of ensuring the D-MILE is safe for consumer use, we will take steps to minimize risks such as isolating the beam path of our laser and strictly adhering to rules and regulations pertaining to the operation of a laser as dictated by their class. To expand this concept, several subsystem options are expanded on in the paper.

(C2.0) To ensure the D-MILE is easy to use, we want to have the firmware used by the printer interact with user-friendly software that accepts common files that are readily available by most users, and to have a convenient means to transmit files to the D-MILE for printing.

(C3.0) Given that the project is entirely self-funded, the cost to produce the D-MILE needs to stay within budget without compromising any core goals.

(C4.0/A6.0) Our laser will have an optical system to support its function and create a specific spot size at a predetermined and convenient location.

(C5.0) Our system will have a series of motors to give access to moving the laser focus freely in x and y. (A5.0/S2.0) Resources allowing, this objective will expand into the z direction with or without constraint. (A4.0/S1.0) As well, we would like to increase the level of ambition regarding the DPI of our system.

(A1.0) As the current focus of the project is a single media of our choosing, we would like to expand this to more than just one. This does not mean users can print or engrave on anything, as such a behavior would compromise consumer safety should the user not have the requisite understanding of the effects a laser can have on different media.

(C6.0/A2.0) Written broadly, we will outline multiple optical subsystems to operate in tandem with the laser system, and would like to be able to include more than one of these subsystems, resources allowing.

(A3.0) Gradients could be produced by a Gaussian beam if we are able to quickly modulate the power delivered to the laser diode, or by controlling the beam path in time as well as x and y.

(S3.0) As materials change, it would be nice to be able to auto-adjust the material into the focus of the beam to ensure the precision of the laser is not affected. This process could even be adjusted and intertwined with the motor control to allow real-time changes of the z direction during printing.



Requirement Specifications

ID	Core Objective Requirements
C1.0	D-MILE complies with any and all safety requirements outlined
C2.0	Project will not exceed \$1000.00
C3.0	Laser spot size will be at most 0.25" in diameter
C4.0	Motor Control will be, at minimum, 50-100 DPI
C5.0	System will not exceed 4ft x 4ft x 4ft in size, weight less than 100lbs, and use a standard USA Type A Power Cord
C6.0	At least one optical subsystem will function

ID	Advanced Objective Requirements
A1.0	D-MILE can etch onto A4 Paper and non-composite/treated wood media
A2.0	At least two optical subsystems will function
A3.0	Print methods include gradients available beyond strict simple contrast
A4.0	Motor Control will exceed 150 DPI
A5.0	The base of the print bed will be capable of moving in the z-direction $\pm 5\text{mm}$
A6.0	Laser Spot Size will be at or under $\frac{1}{8}$ " in diameter

ID	Stretch Objective Requirements
S1.0	Motor Control of 300 DPI or better
S2.0	Motor Control extends to the z-direction, allowing for variability in z to be factored into print maps
S3.0	The platform and laser will coordinate to auto-focus onto the material surface



Motivation

Inkless Printers exist, but they use toner. Ink and Toner both can run out, and you need to pay outrageous prices to specific companies to buy compatible products to use your printer. Not only that, ink can be toxic or dangerous to the environment, and toner is carcinogenic if inhaled.

Another key aspect of our project was the idea of expanding upon the tactile feel that results from an etch onto paper, rather than just wood. This would allow us to print braille and enable printing for the visually impaired.

We also wanted to improve upon the results and viability of this project from previous attempts by other groups in years past, as well as adding other features we felt added sufficient value

Constraints

- **Safety**
 - Laser light from powerful lasers can cause permanent damage to vision and skin, and so preventing the harm caused by the laser is of the utmost importance to our project.
- **Environment**
 - Our project is meant to replace ink or toner printing which leads to byproducts or makes use of consumables which can be potentially damaging to the environment, as a result, our project needs to be safe to be near and not rely on anything hazardous.
- **Economics**
 - Our project is entirely paid out of pocket due to the lack of any sponsorship. This places more stress on us to pick solutions which are more budget friendly, but may require more work or function less than we may like.
- **Electrical**
 - Since this is a consumer-oriented product, it needs to be compatible with standard wall outlets in the USA.



Block Diagram

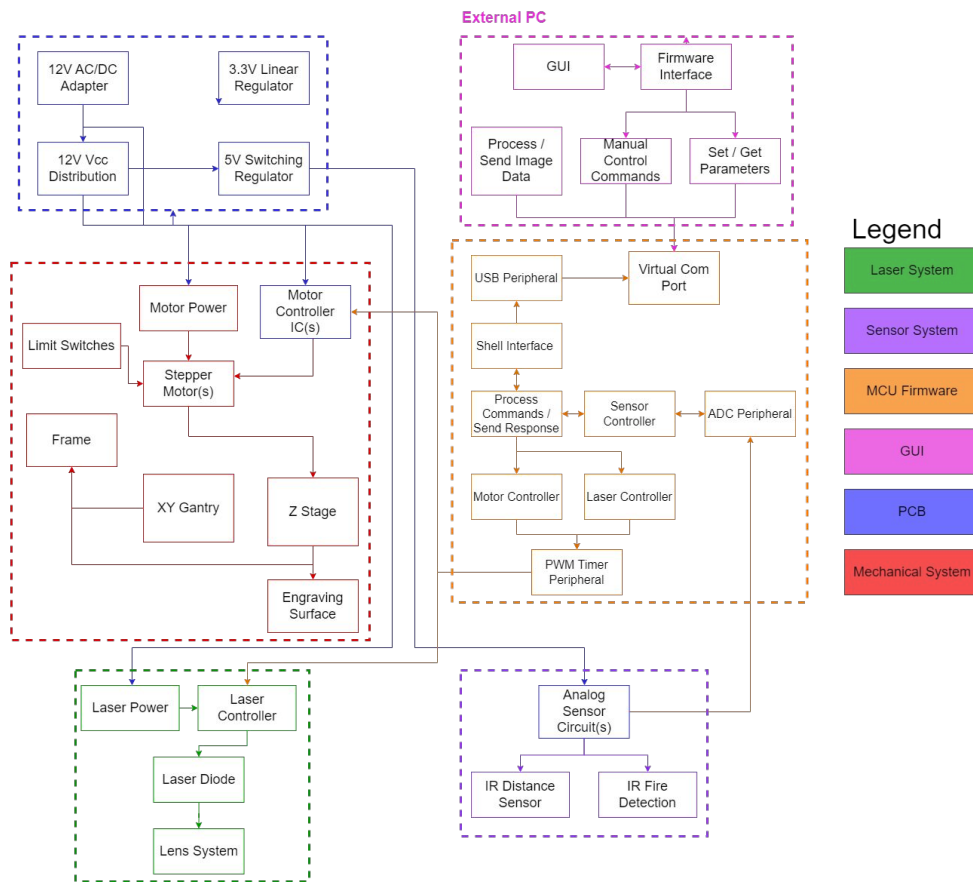



Mechanical Frame

- The mechanical frame is made out of 80-20
- Frame is sturdy and is able to hold everything we need

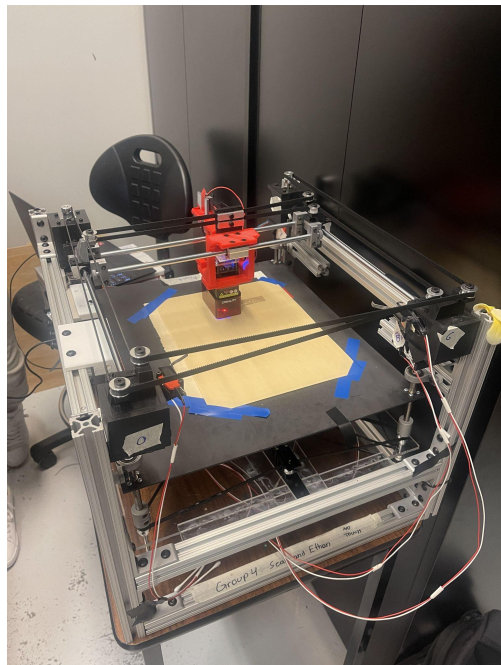



XY Gantry - Overall Design

- A belt system is used to move the laser over the print area
- The gantry is constructed with 3d printed parts and aluminum rods, gears, and linear bearings
- Corners are mounted to the stationary frame for stability using L brackets and 3d-printed clamps

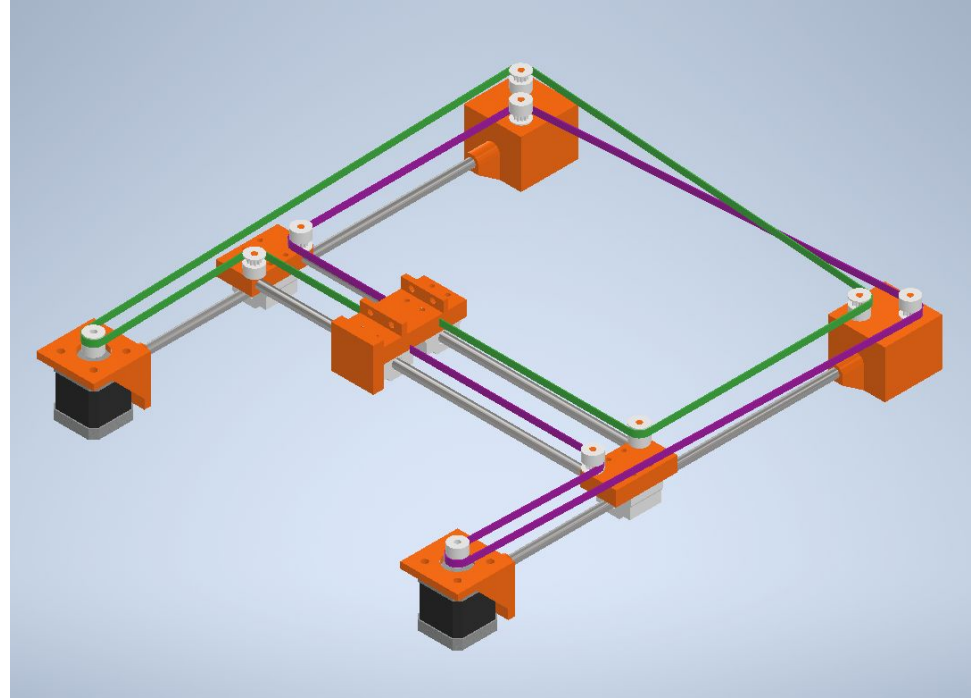



XY Gantry - Function and Benefits

- Driving both motors in the same direction results in X axis movement
- Driving each motor in opposite directions results in Y axis movement
- Benefits:
 - Side-mounted motors reduces load weight
 - Simpler wiring
 - Cheaper construction than threaded rod design

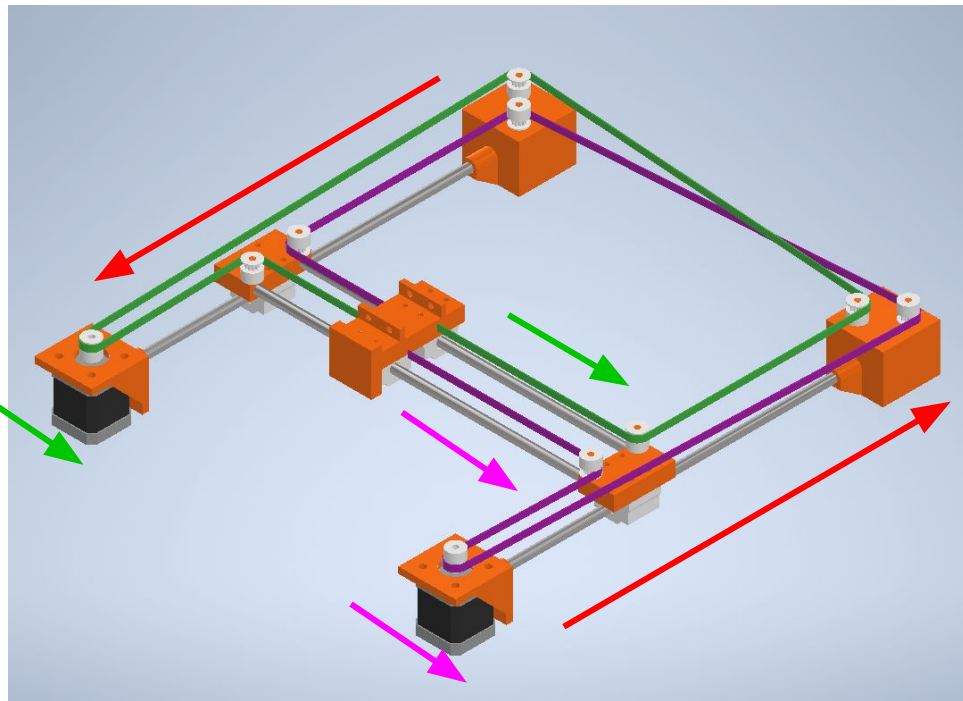



XY Gantry - Function and Benefits

- Driving both motors in the same direction results in X axis movement
- Driving each motor in opposite directions results in Y axis movement
- Benefits:
 - Side-mounted motors reduces load weight
 - Simpler wiring
 - Cheaper construction than threaded rod design

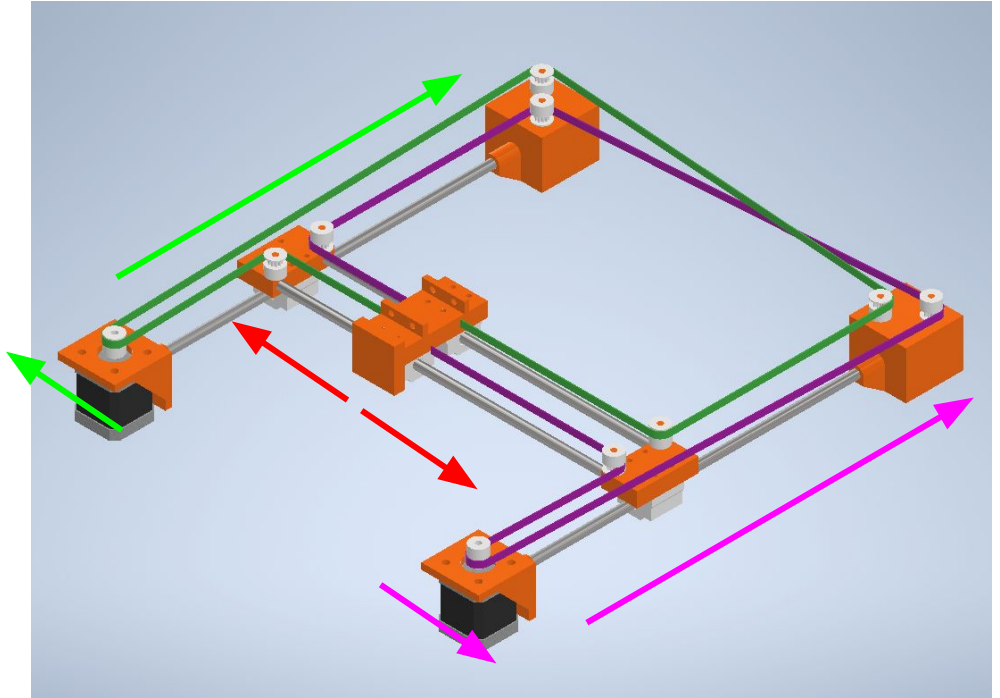



XY Gantry - Movement

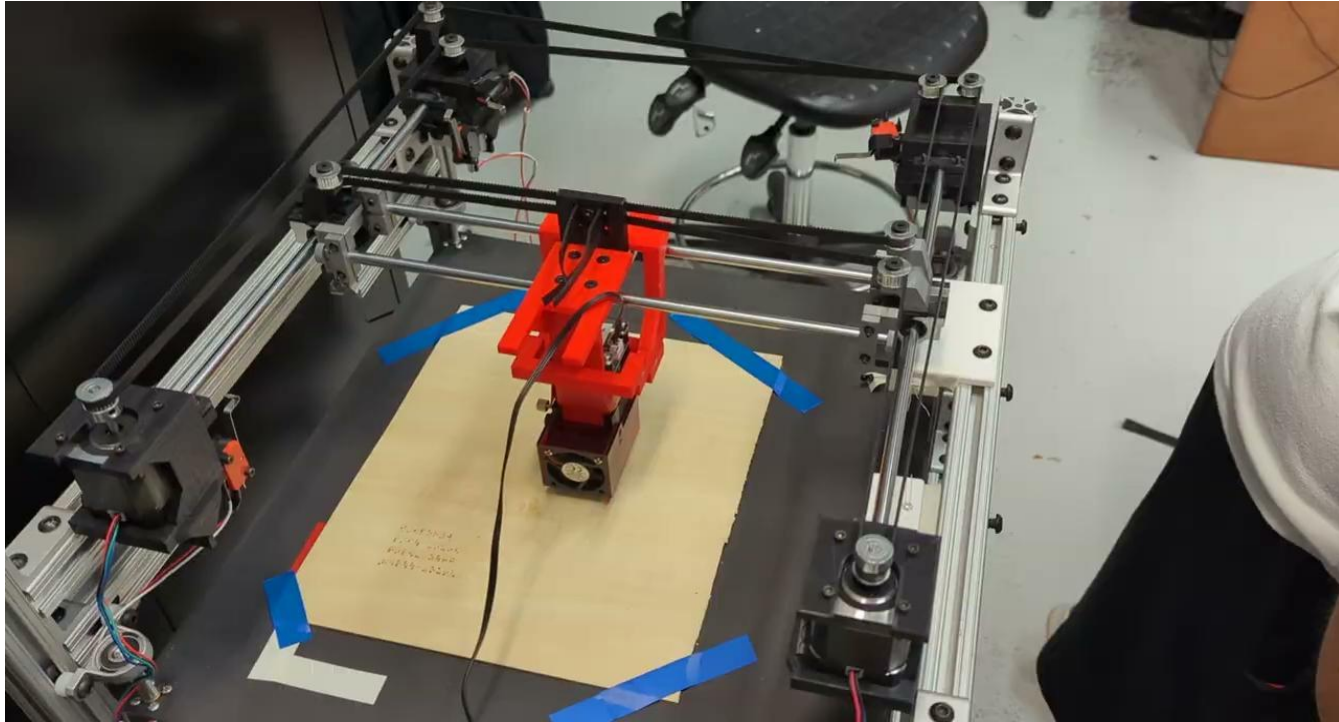



Z Axis

- The Z axis of the engraving area needs to be adjustable to account for different material heights
- Uses a motor to move the movement stage
- This will be done with threaded rods, similar to common 3d printer designs
- 100mm threaded rod, this allows for about 85 mm in movement

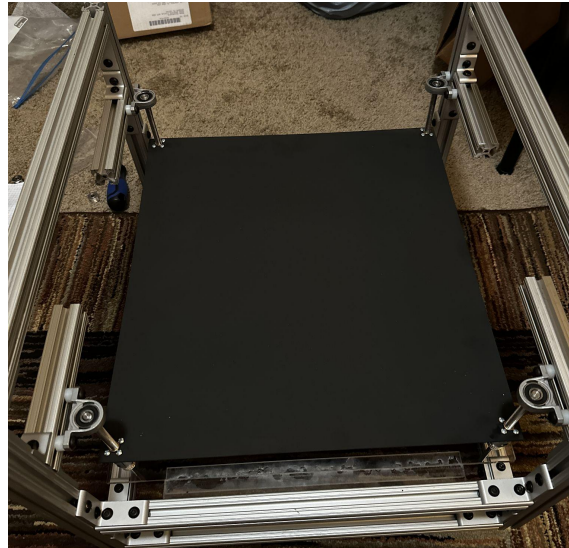
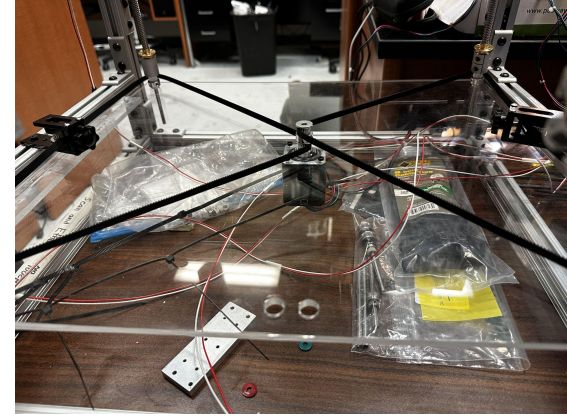



Firmware Design - Structure

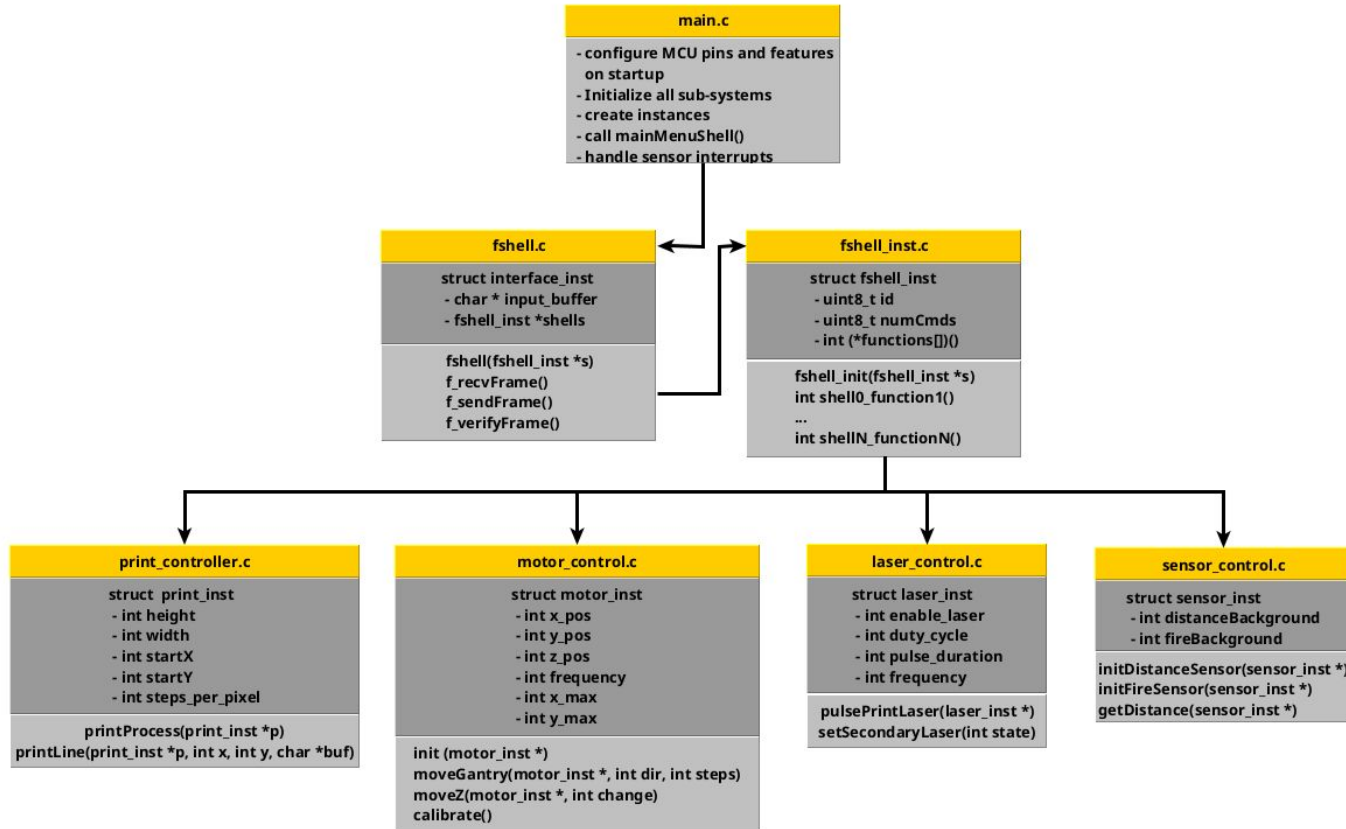



Firmware Design - USB Communication

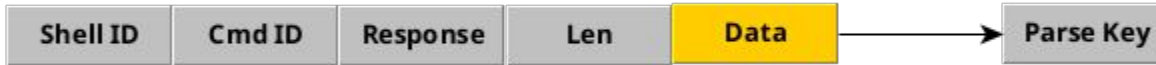

Legend





Firmware Design - Program Flow

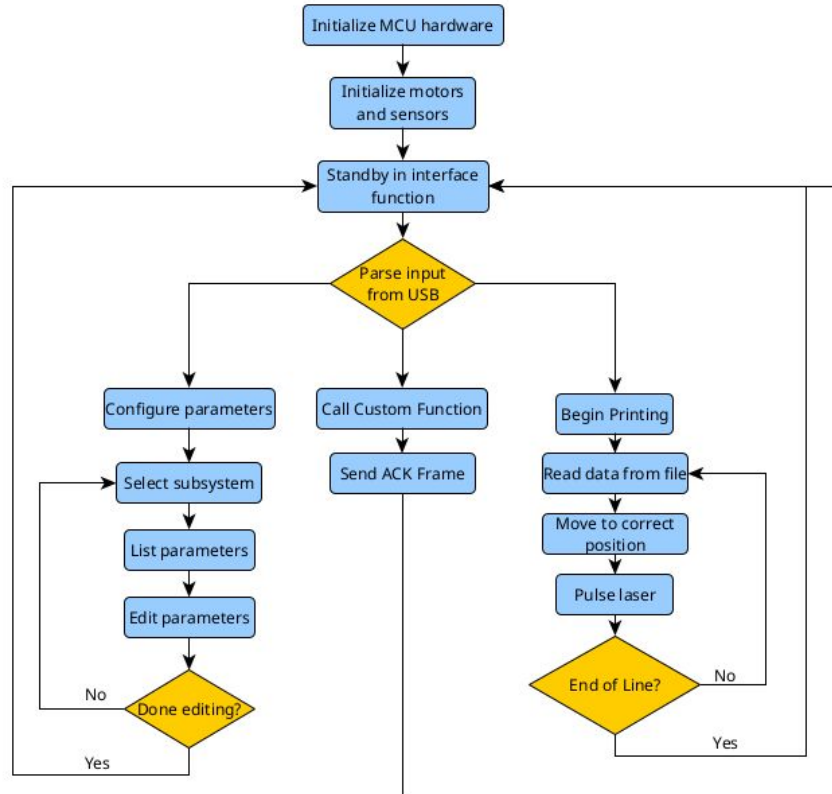



GUI - Document Processing

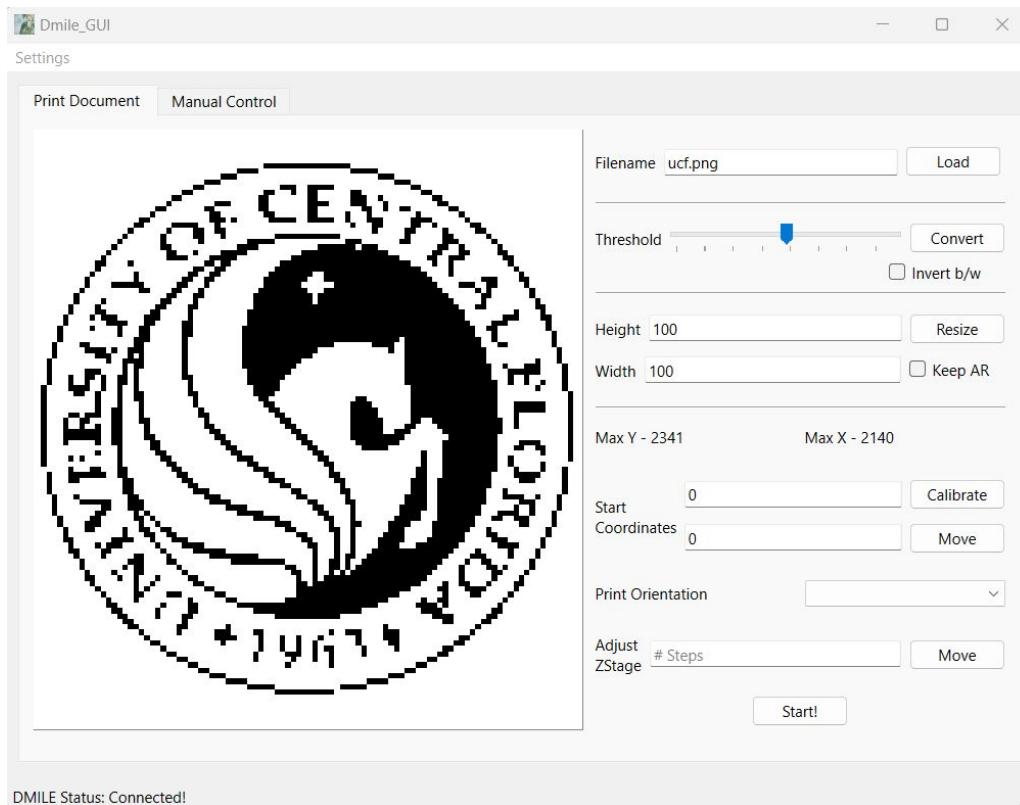



GUI - Manual Control

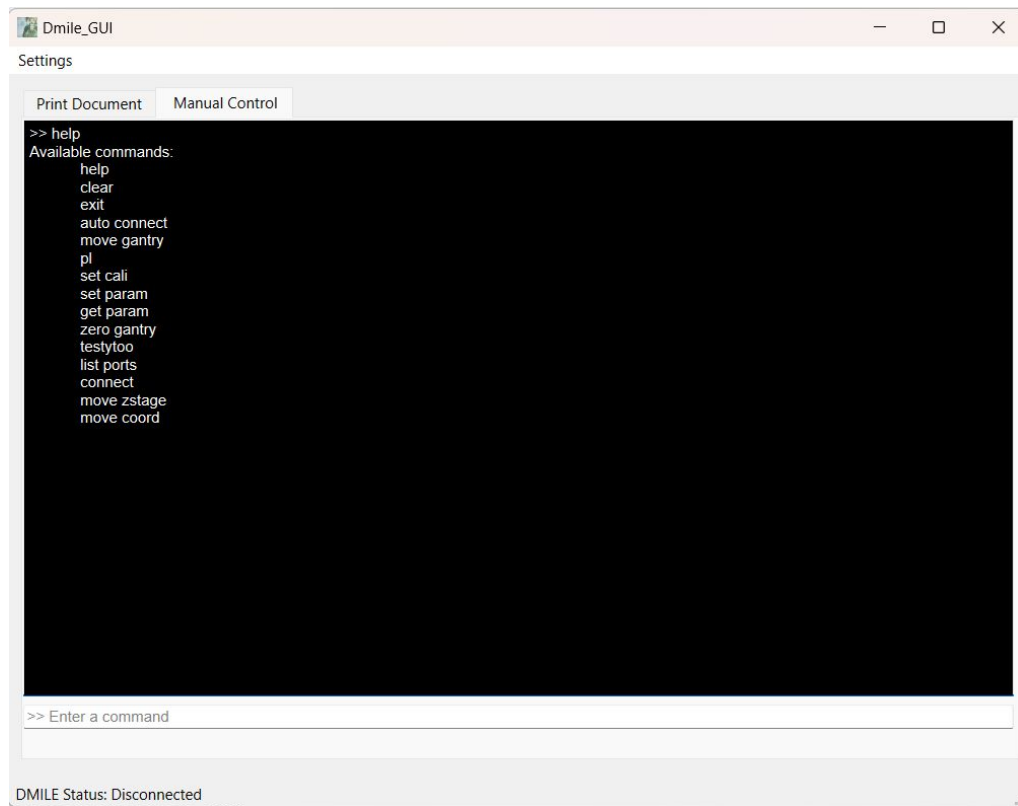



GUI - Firmware Settings

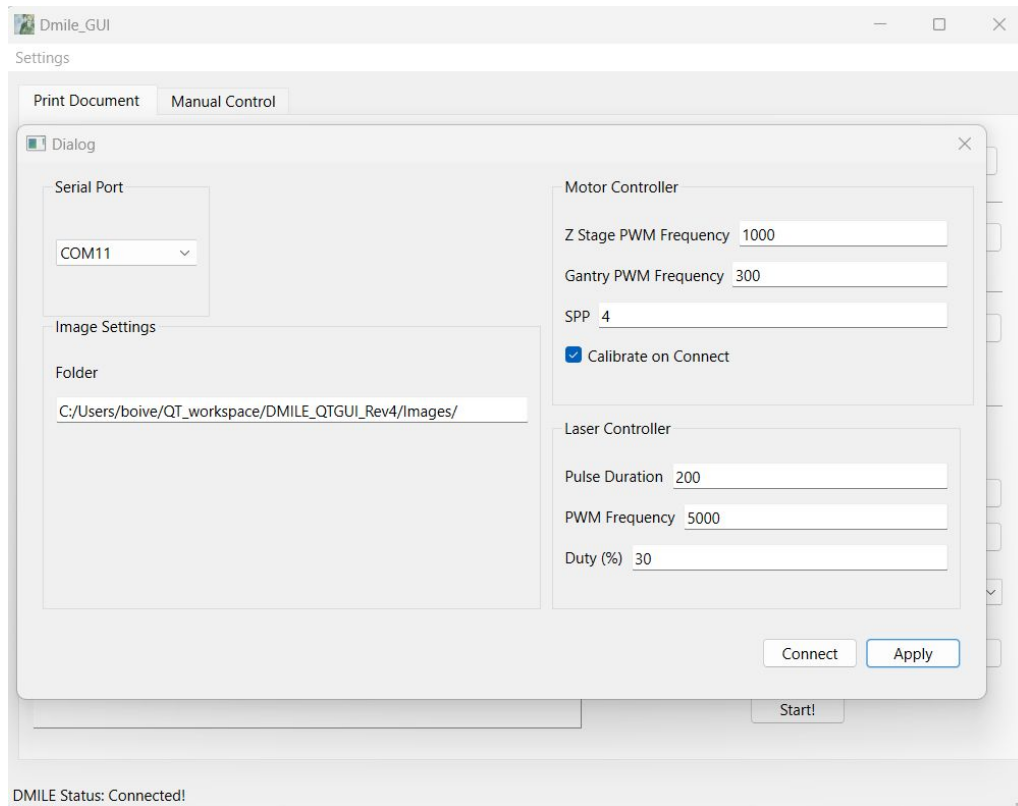



Firmware Design - Remaining Tasks

- Integrate components together
- Test integrated firmware with hardware prototype
- Create UI frontend software to automate communication over USB

Power Regulation Flow Chart

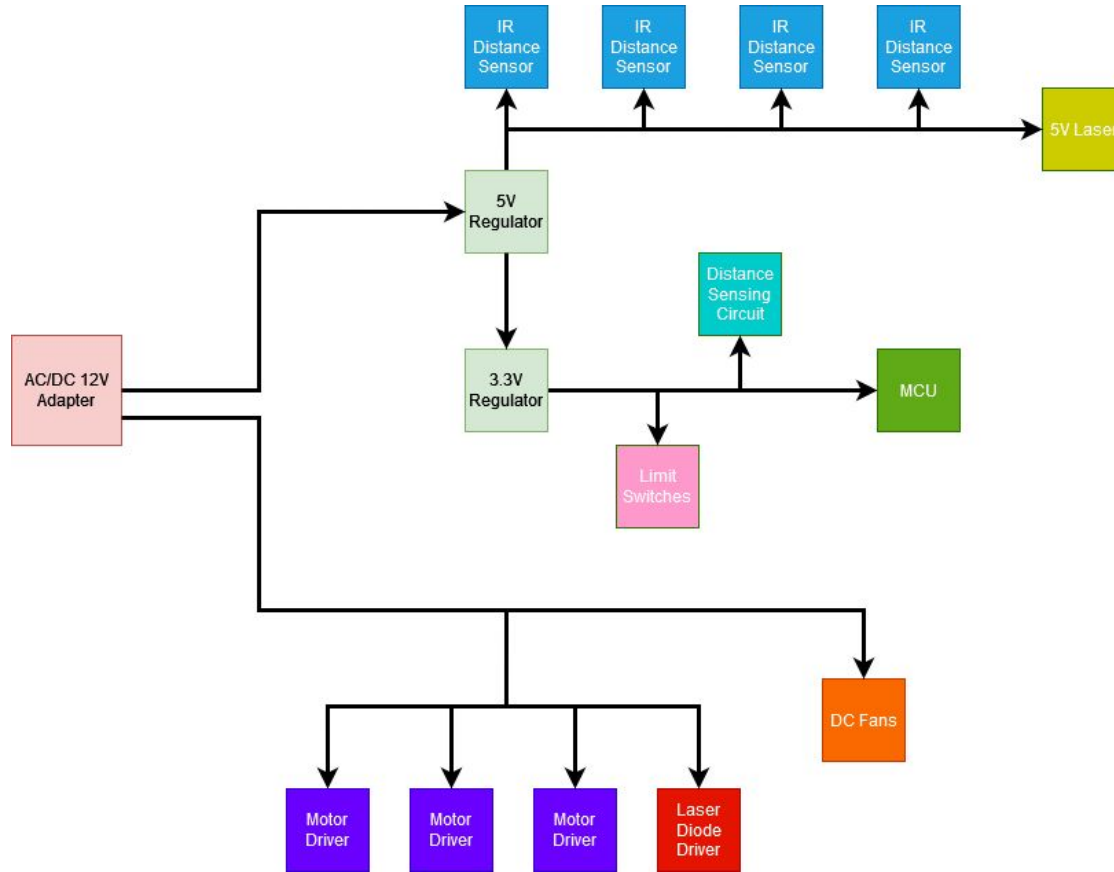

PCB Key Parts - LMR51420



- The LMR5140 is a switching buck regulator that will allow us to step down input voltage to whatever is necessary
- Adjustable regulator, meaning we need to select the right resistor for a desired 5V output

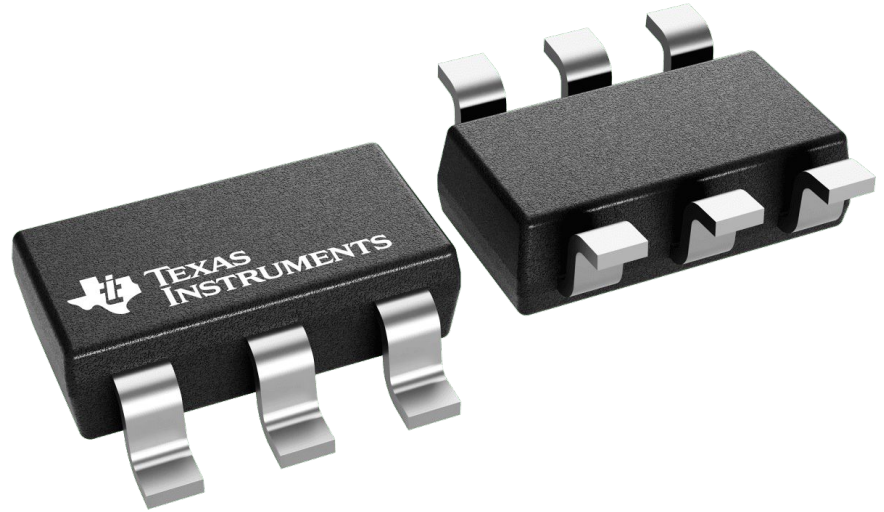

PCB Key Parts - AZ1117



- This is a linear regulator that will give us a 3.3V output that is necessary for MCU operation
- The 5V switching regulator is used as input for this regulator
- A small filter will be added at the output for analog use

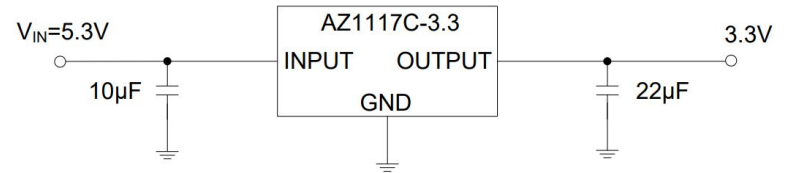
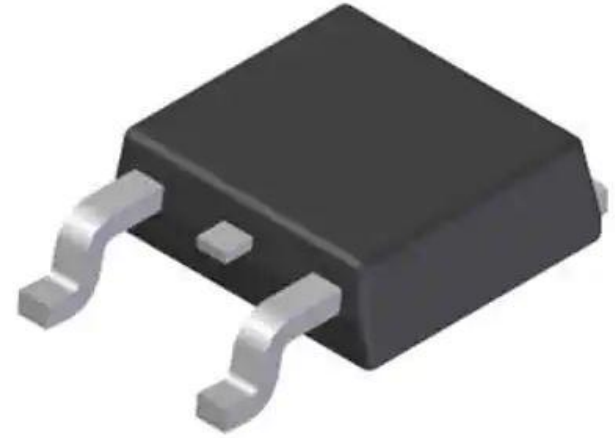

PCB Key Parts - DRV8825

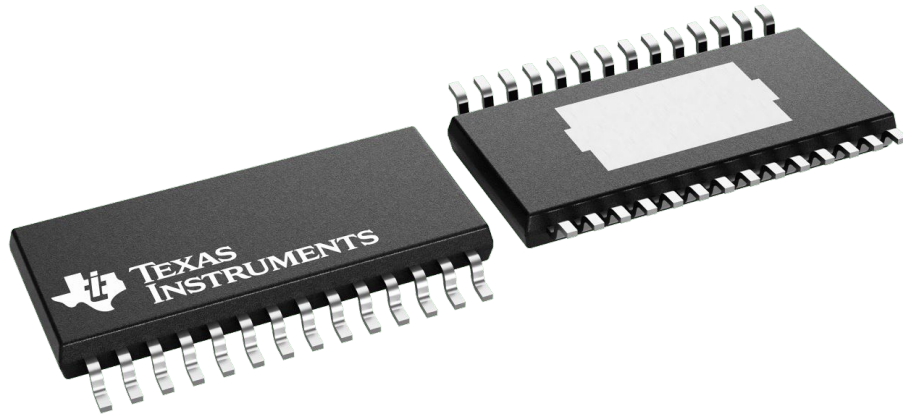

- The DRV8825 motor controller allows us to control our bipolar stepper motors with microcontroller inputs
- 3 needed for each motor

PCB Key Parts - TSV912



- The TSV912 is a simple Op-Amp that is used in our distance sensing circuit to allow our microcontroller to read its analog voltage output
- 4 distance sensors are in our design, so 2 of these chips are required

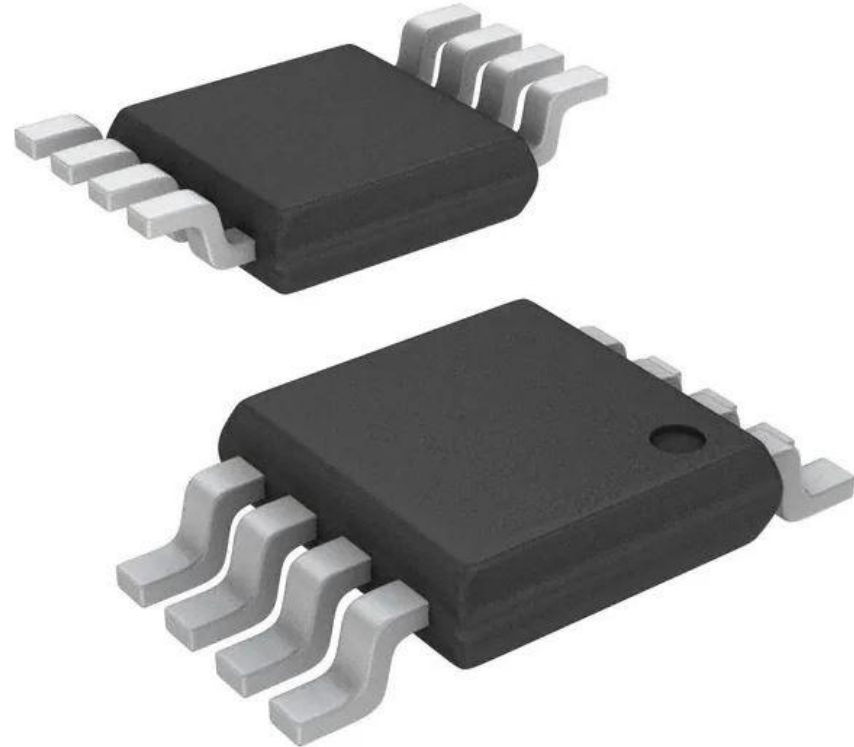

PCB Schematic

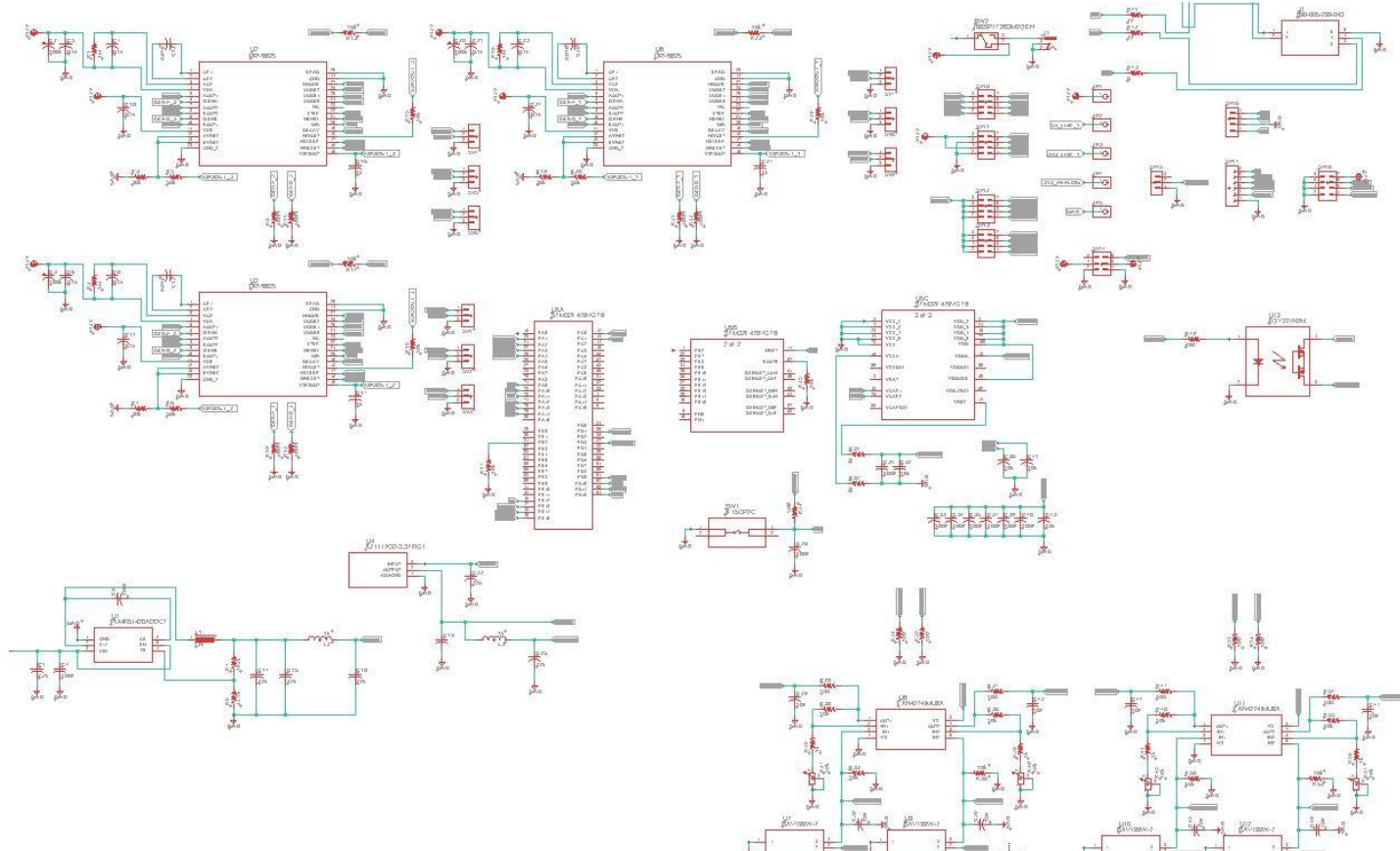



Power Regulation Schematics - 5V

- LMR51420 regulator allows a 4.5V-36V input range and adjustable output
- Resistor and inductance values chosen with the aid of WEBENCH Power Designer

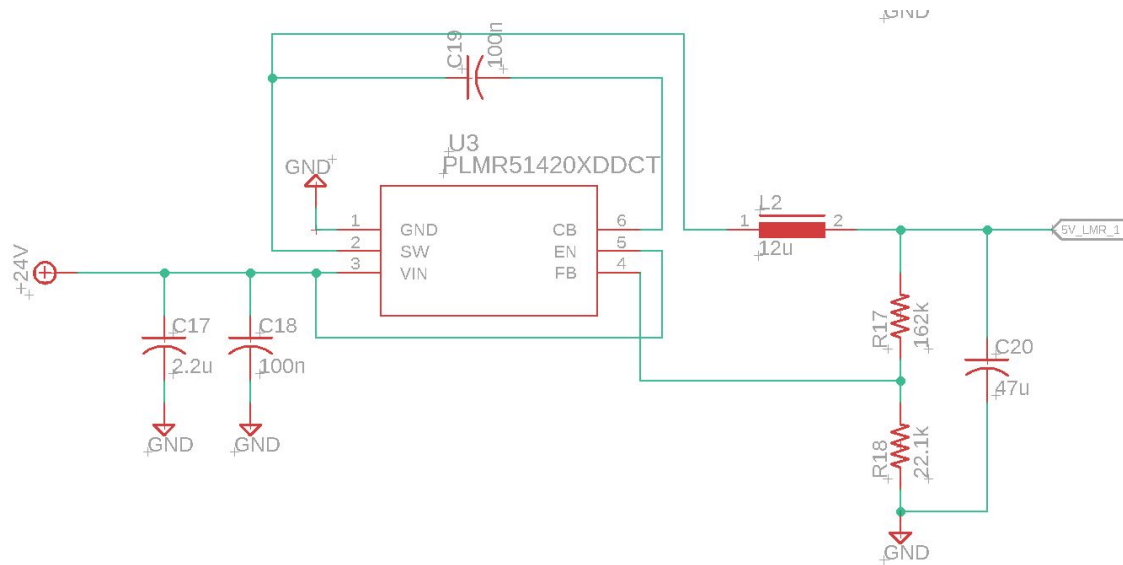



Power Regulation Schematics- 3.3V

- The AZ1117 3.3V dropout regulator is cheaper and less noisy than an extra buck regulator
- No adjustment resistors required
- A small filter is placed at its output for the use of analog circuits that use 3.3V

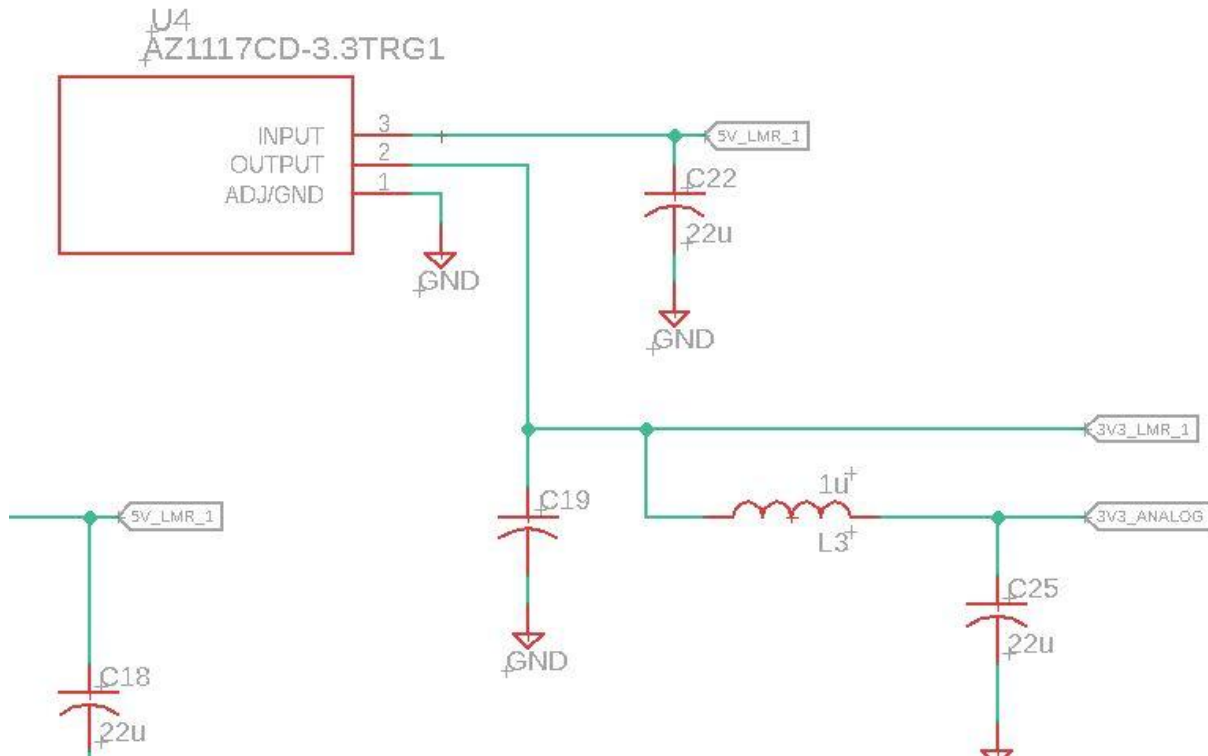



Motor Driver Schematic - DRV8825

- The datasheet provides the schematic for typical application of the DRV8825, which is used here
- MODE Pins on the right are used to manually program specific step modes for our controllers

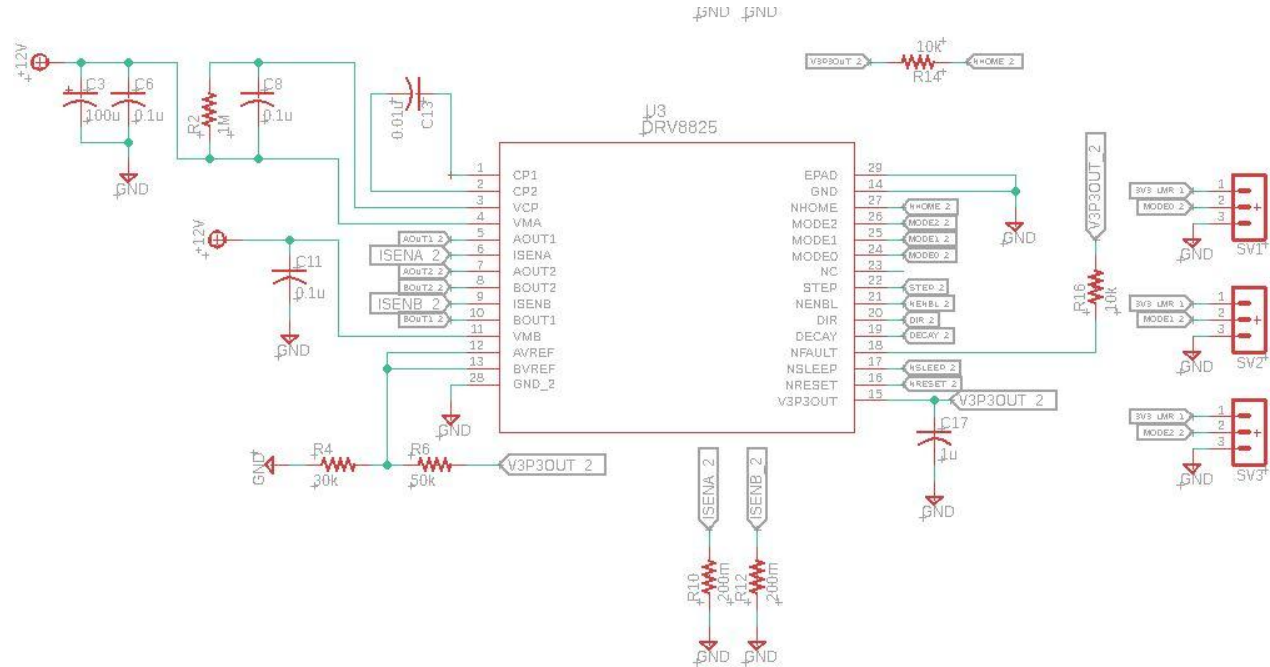



Distance Sensor Schematic - TSV912

- The IR LED and IR Photodiode used in the sensor are mounted on the chassis and connected to the PCB with wires
- The output is an analog value that is read by the microcontroller to determine distance

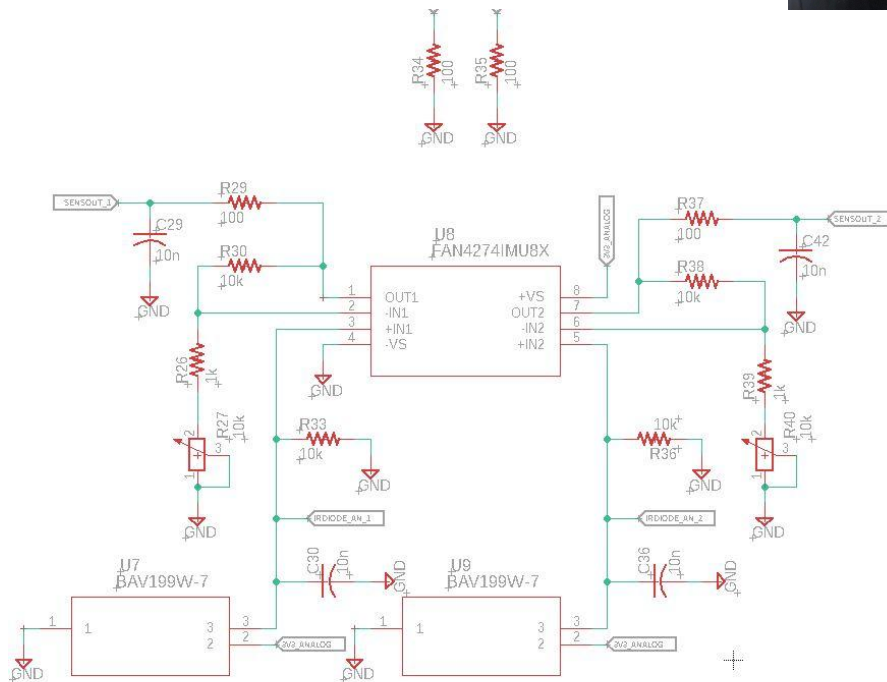



External Connections

- Several external connections from the main PCB are required for our device to function

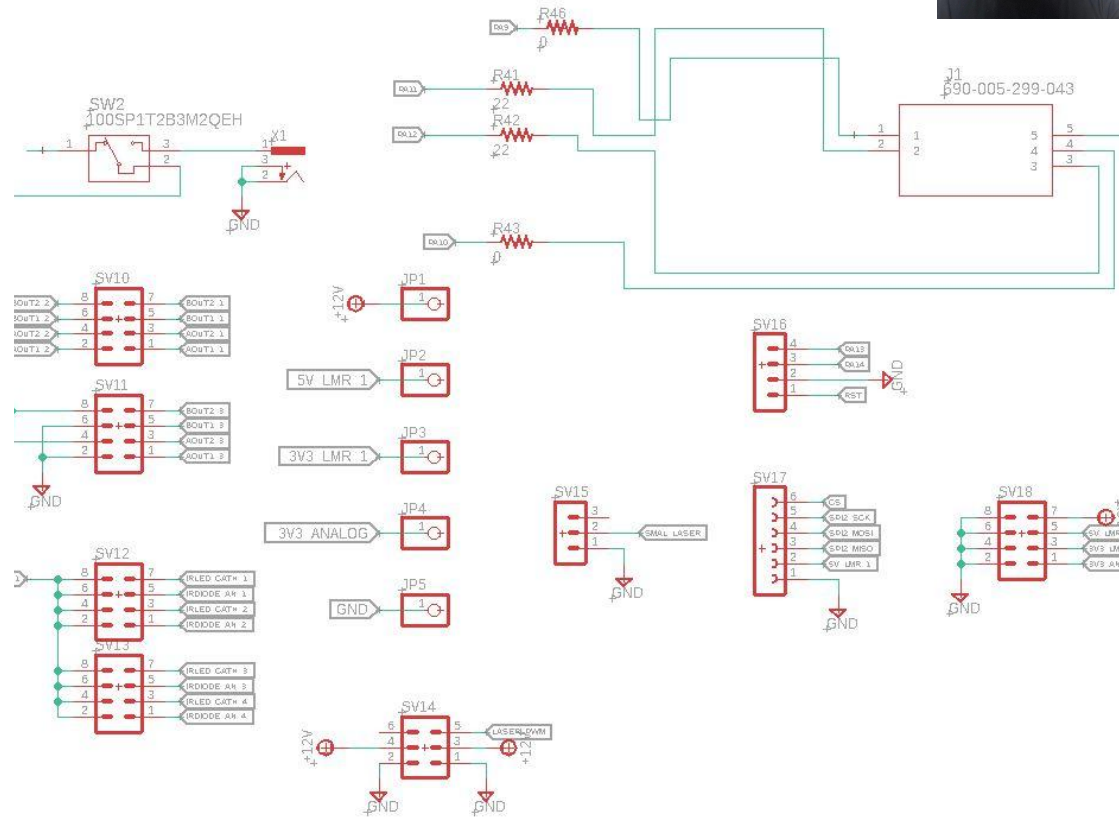



External Connections - AC/DC 12V Adapter Jack

- Power source for the entire device is 12VDC from an external power adapter
- A master switch is used in series to control all the power to the PCB

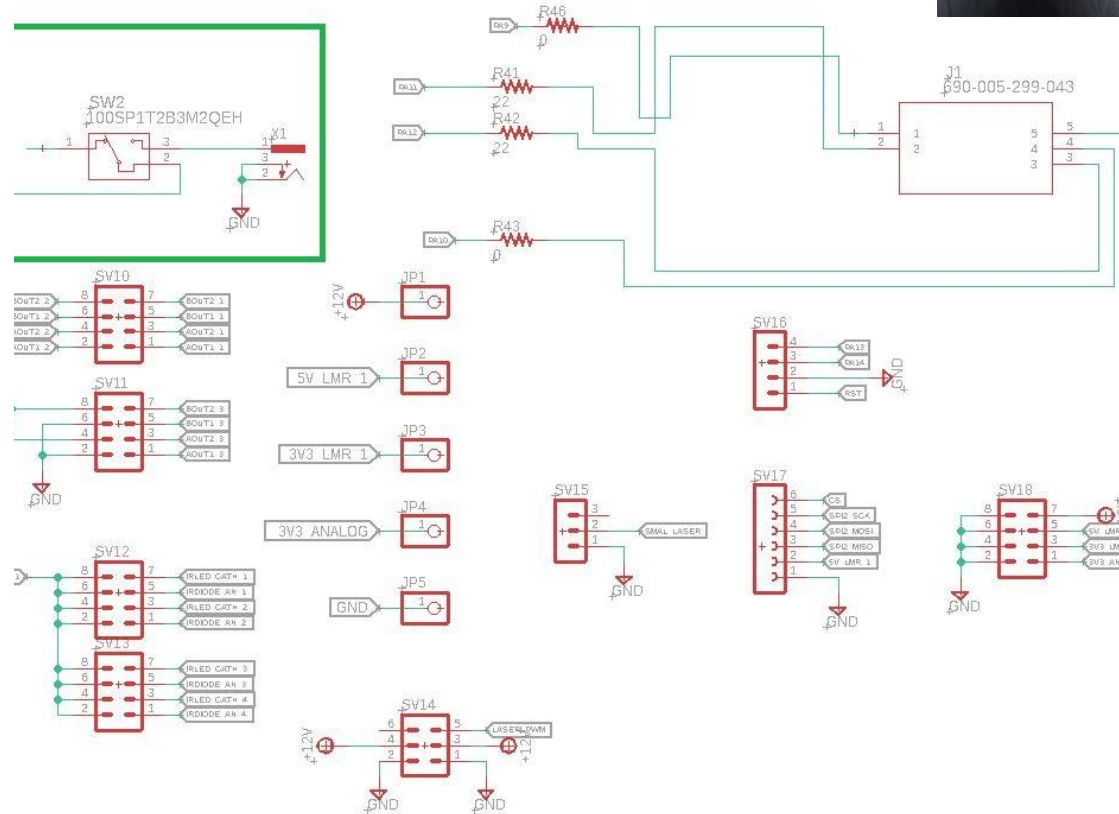



External Connections - Laser Diode Pins

- The laser diode has two pins for power and ground and, and one pin for PWM signal from the microcontroller

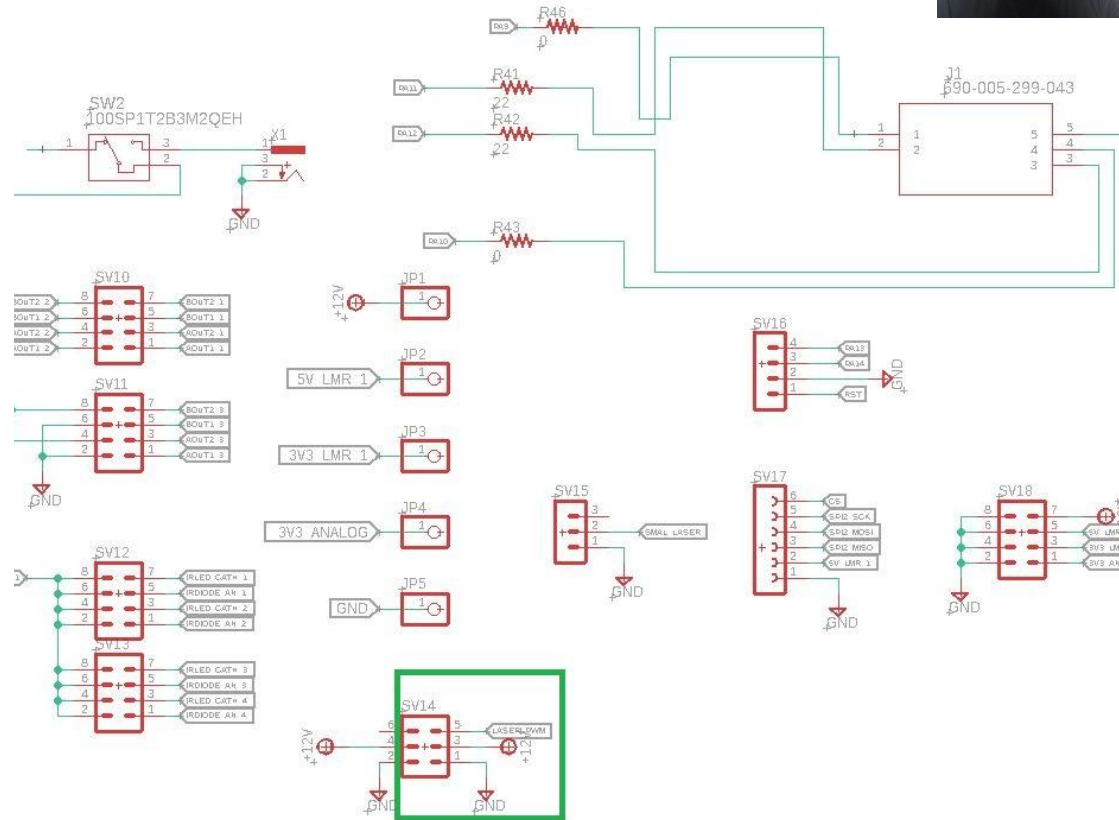



External Connections - Mini USB

- A mini-USB connector to communicate with the microcontroller and use the GUI

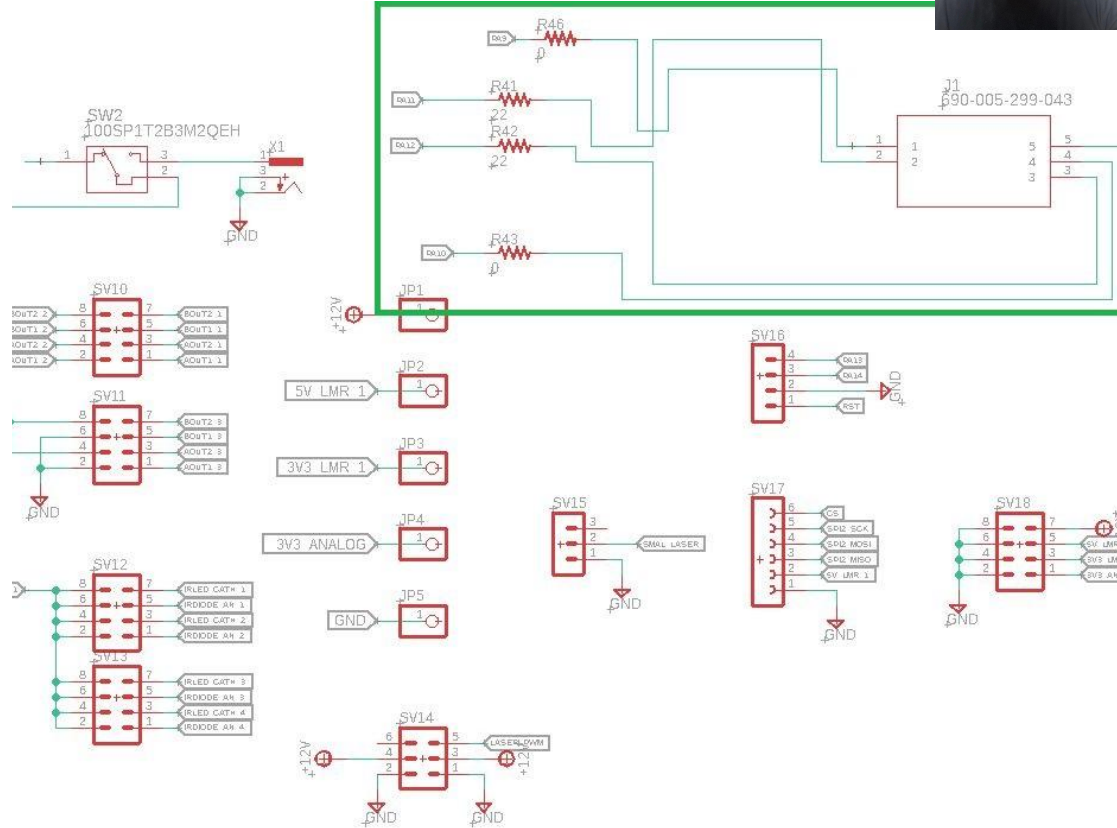



External Connections - Distance Sensor Diodes and LEDs

- The IR LEDs and IR Photodiodes are mounted on the chassis
- Through cables and pin headers they are connected to the sensor circuits

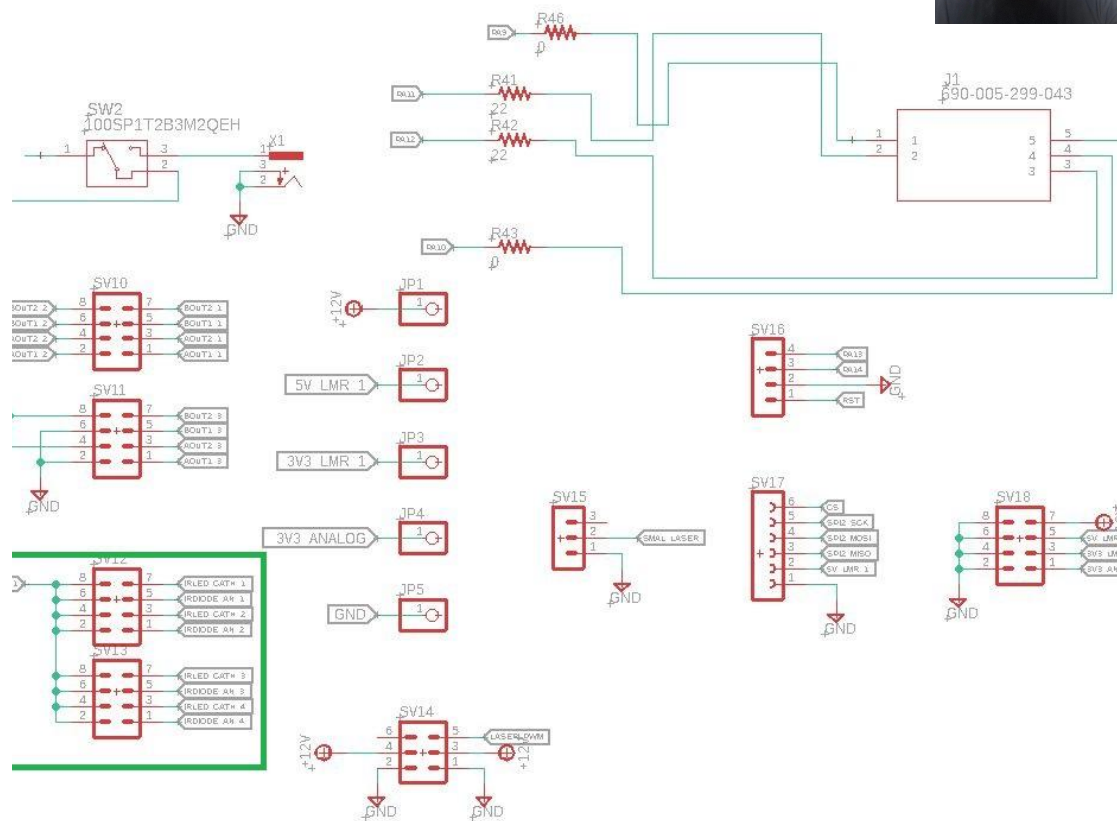



External Connections - Stepper Motor

- Each stepper motor requires four pin connections to each motor driver
- 12 pins are used for three stepper motors, one for each X, Y, and Z axis of movement

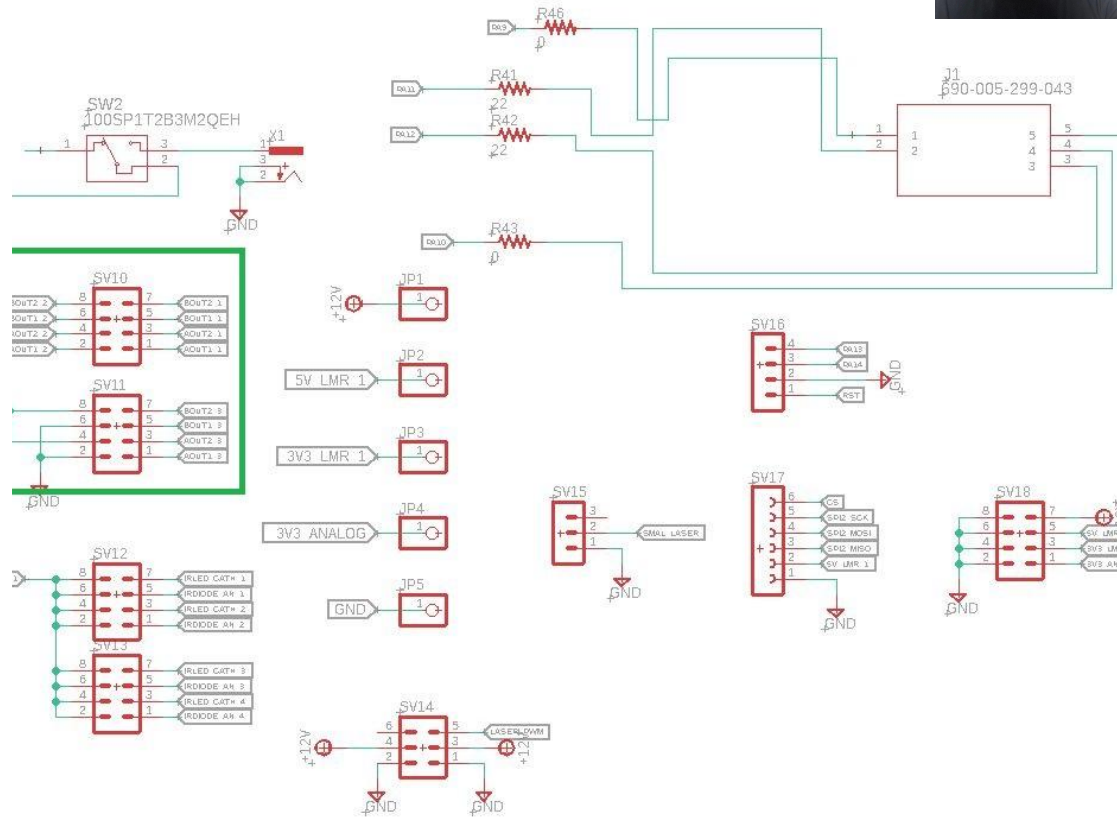



External Connections - 4-Pin Programmer

- This 4 pin header is necessary for programming the microcontroller and debugging

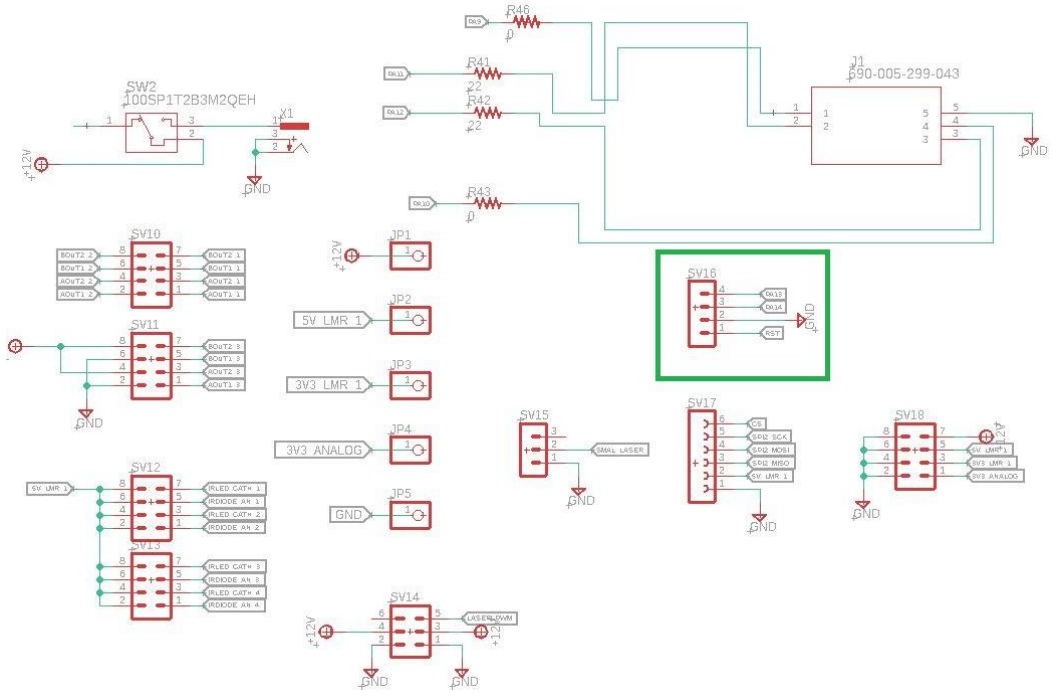



External Connections - Limit Switches

- Previously intended for an SD card module, these pins were instead repurposed for the use of limit switches to aid in movement and calibration of our gantry

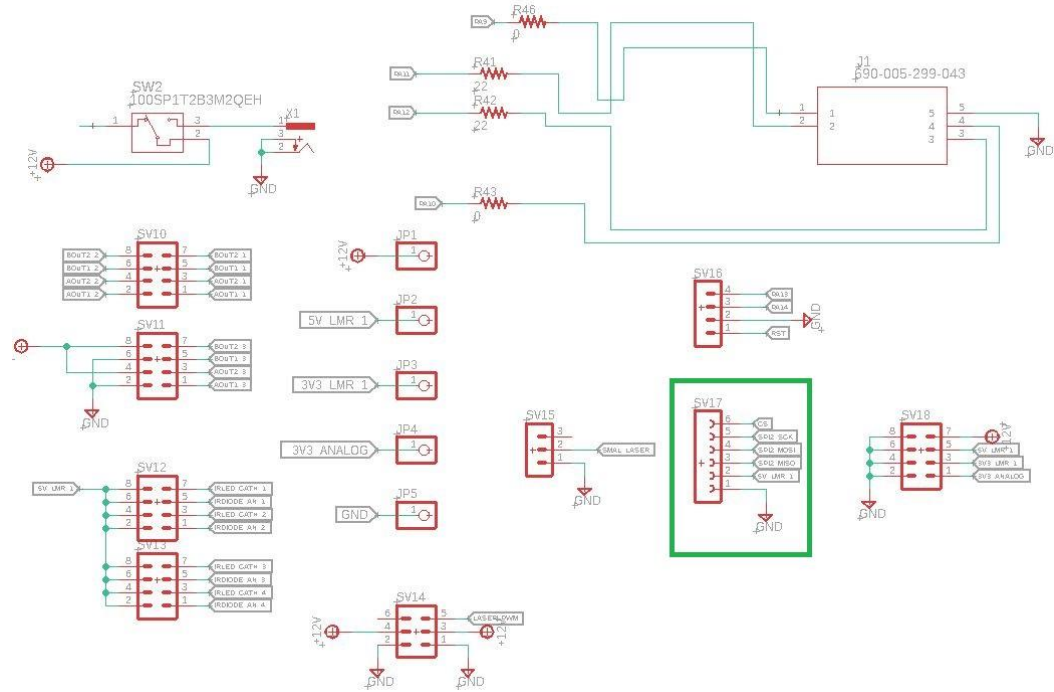

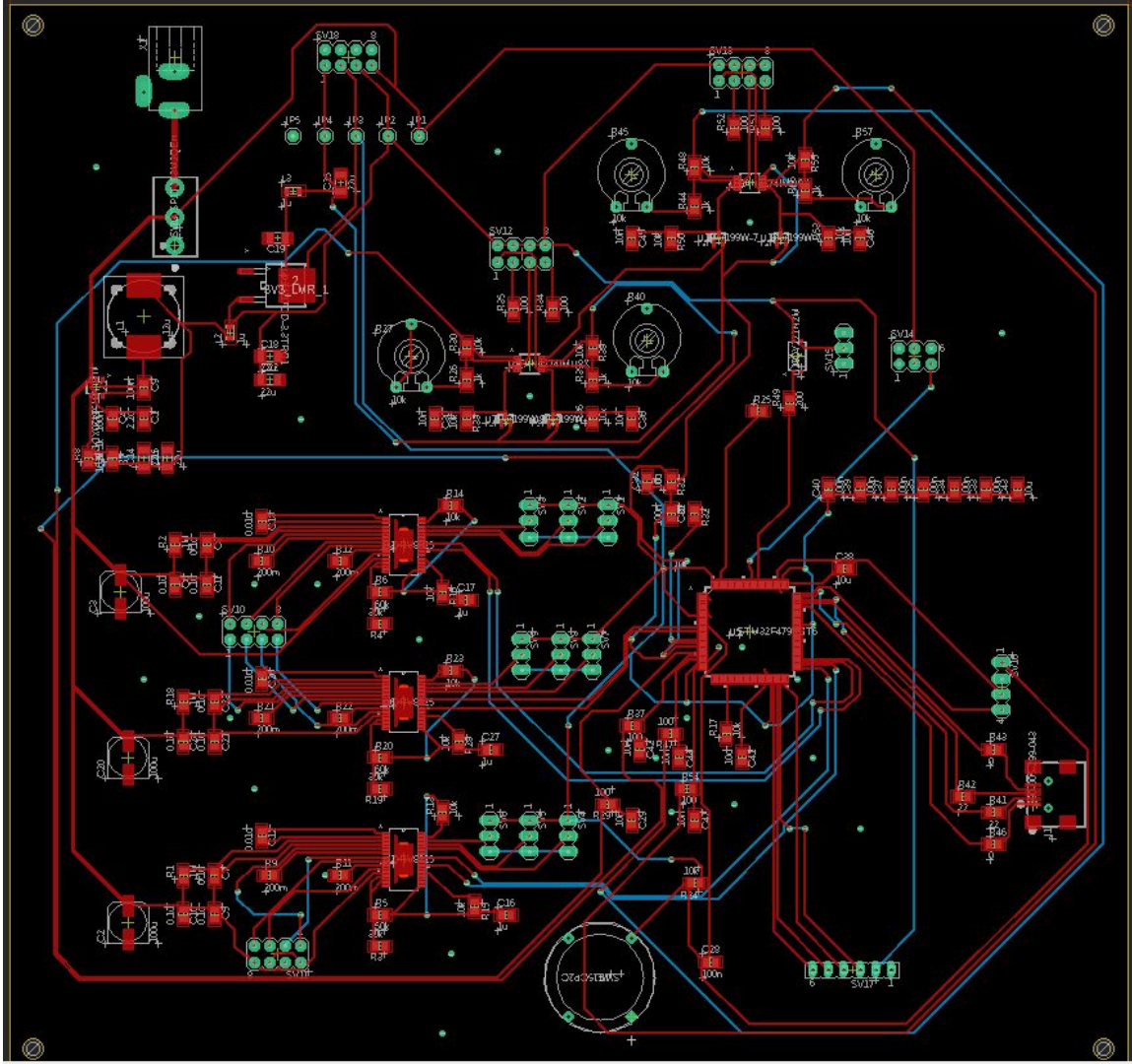

**Power
Regulation**

**Analog Sensing
Circuits**

**Motor Controller Circuits
+ MODE Pins**

MCU

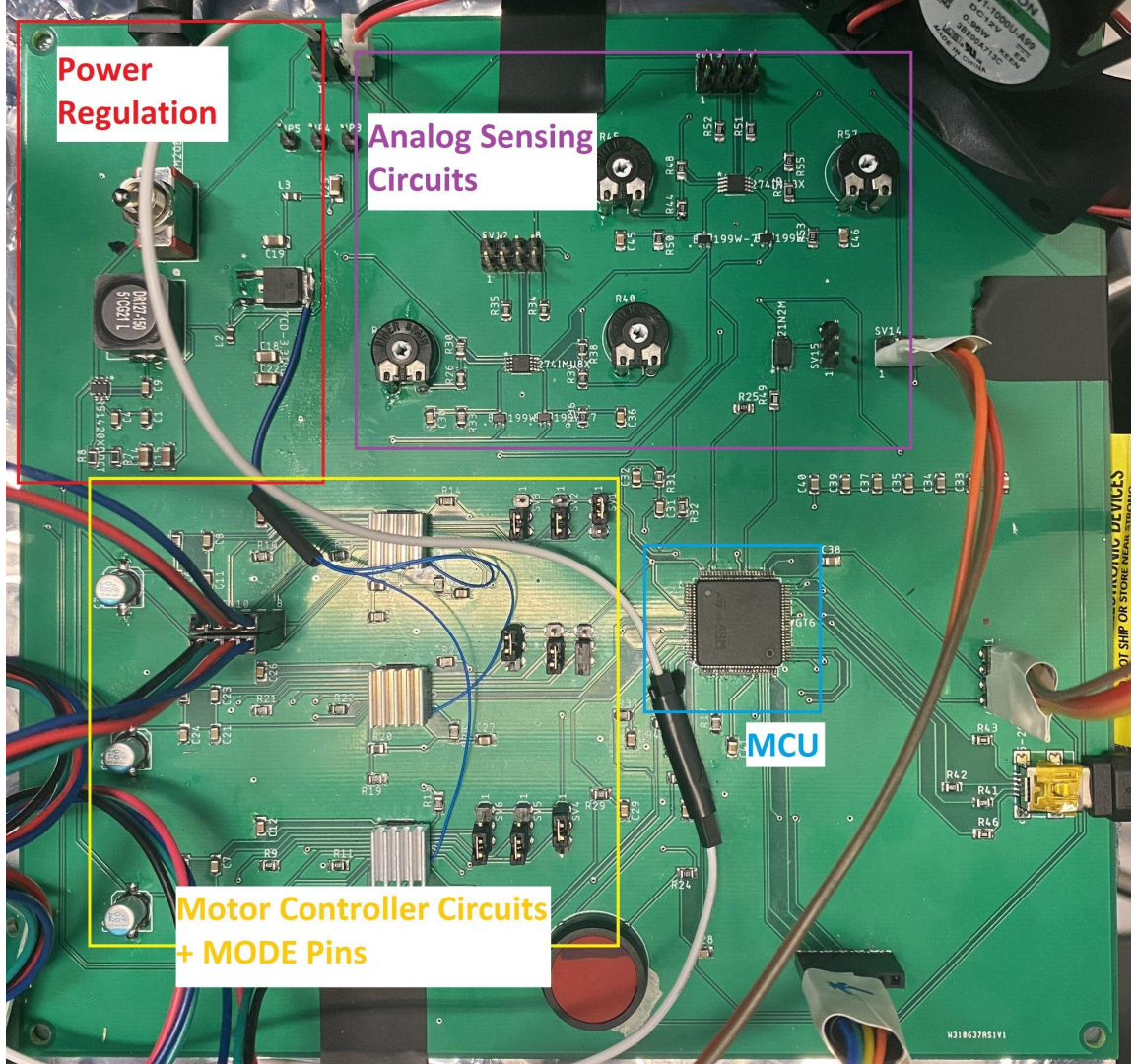



Laser

With attached specifications, the laser is capable of etching safely (without causing fires) onto:

- Paper
- Cardstock
- Wood (Excluding Composites)

Laser is compact and lightweight, with inbuilt screws for mounting to the mechanical gantry.



Fig. ###. Laser used in Optical Engraving Process

Specifications:

Dimensions: 3.3cm x 3.3cm x 10cm
Turn on Conditions: 50% Duty
Cycle, 5V_{PP} Amplification, 0.5 Watts
Input Power, 405 nm Wavelength,
237 mW Output Power

Class 3R Laser

Safety Goggles must be worn at all times during operation.



Laser - Optical Design

Laser light will be focused to an ideal spot at a distance 140mm away from the laser. The acceptable spot size range¹ will extend closer to the laser by ##mm.

The focusing is accomplished by two identical plano-convex lenses made of N-BK7 glass, positioned at their focal length (38.1mm) away from the laser.

Lens: Newport KPX046 Uncoated Lenses

[1]: Until the beam spot size diverges from ideal by a factor of $\sqrt{2}$

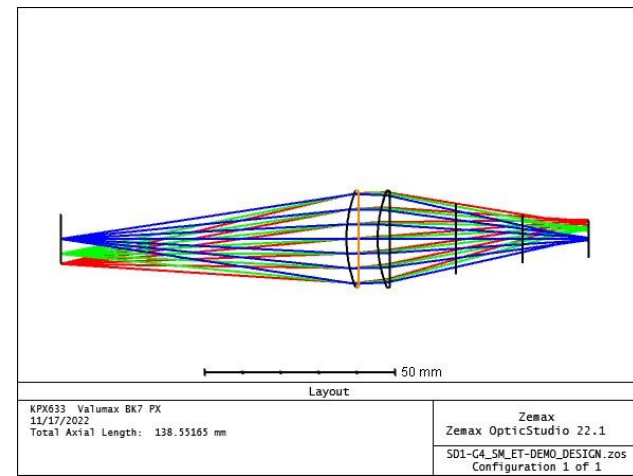
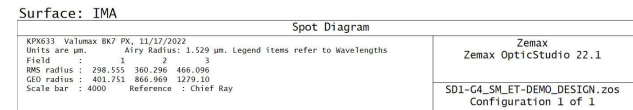
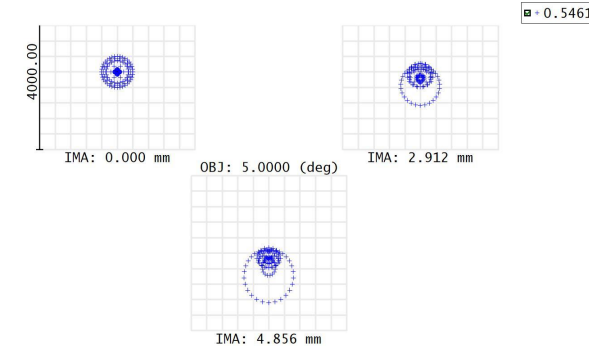

Fig. ###. (Above) Total Optical Design in Zemax, (Below) Spot Size Diagram for on and off axis rays at various points along the path length.





Laser - Focusing Lenses

Common Questions:

Why not make a custom lens?

Pros: Light is focused more effectively, shorter optical track length, less aberration

Cons: Incredibly high price tag, potentially high delivery time

Why use only two lenses?

Pros: Two lenses make the system simple and cost effective while increasing the degrees of freedom during design

Cons: A reduction in potential solutions to aberration problems and limitations on focusing

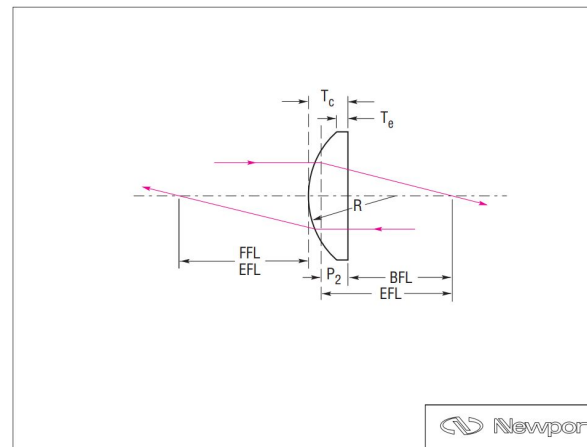

Fig. ###, KPX046 diagram and schematic according to Newport Website



Laser - Prototyping

When designing the mount, the primary objectives were:

- Create a mount that functions and holds the laser and lens system

The secondary objectives were:

- Minimizing complexity for quicker, more efficient 3D prints
- Minimize costs, and improve ease of use
- Allow for mounting of the main laser and print area laser in the same shell
- Allow for variability of lens placements between the laser and lens system

Configuration Laser

Lens

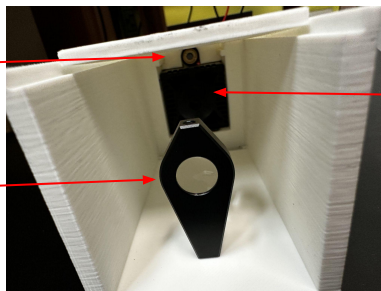

Laser



Adjusting Beam Parameters

To control the beam spot size we can adjust:

- Distance from lens to z-stage
- Distance from lens to laser

Variables we can adjust in the PWM signal:

- Frequency
 - We can run the laser at anywhere from 500Hz to 10kHz
- Duty Cycle
 - We can vary the duty cycle from 0% to 100%

Parameters

- Etch Depth
 - Power
 - Pulse duration
- DPI
 - Spot size
 - XY stage step count

Optimization order

- Laser Spot Size
- PWM Signal
- XY stage step count

Laser - Working

- Originally spec'd laser and lens system exceeded design requirements
- Lens system was optimized to produce optimal results
 - Small spot size
 - High DPI
- Spot size with lens design: 0.025" = 1/40"
- Laser broke days before the showcase

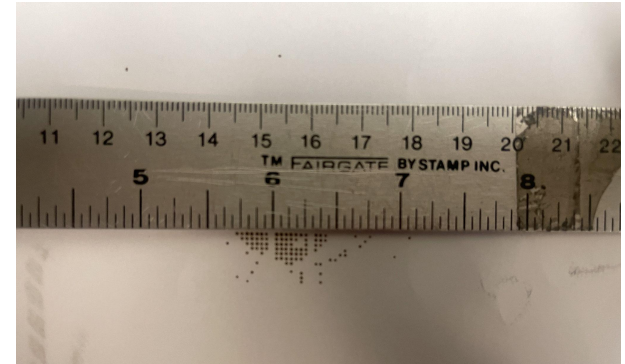
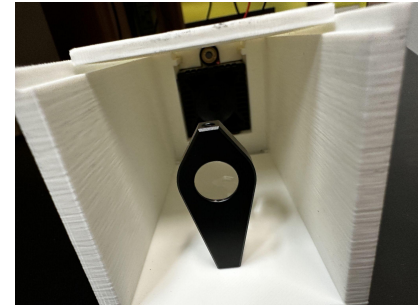
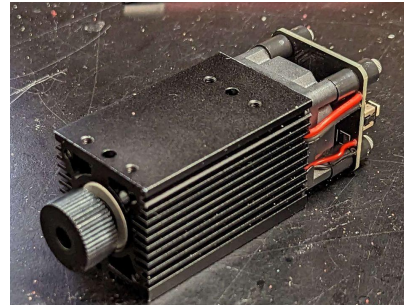

New Laser Module

- Wavelength: 450 nm
- Laser module dimensions required modification
 - Small focal length
- Laser system is modified for superior results
 - Spot Size: 0.02" = 1/50"
 - Slightly higher DPI

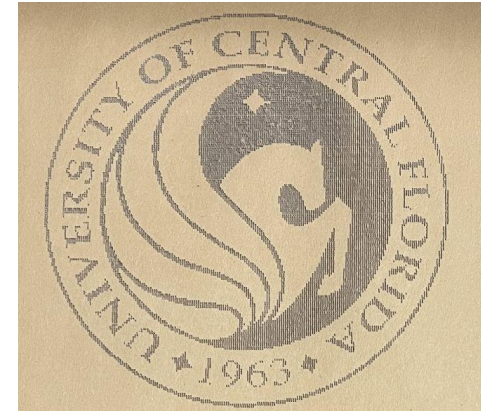
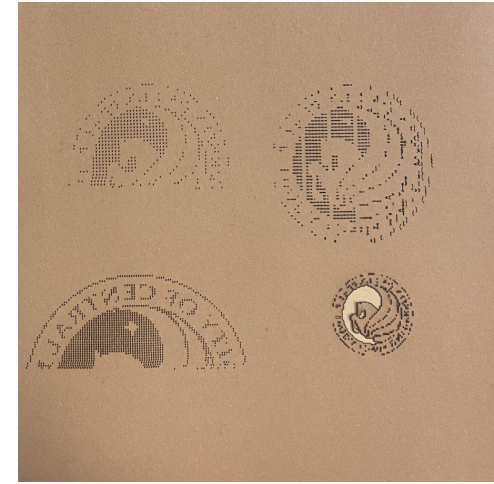

Laser Results

Laser Result Comparison

- Spot Sizes roughly similar
- Backup laser more powerful, shorter pulse duration but larger minimum etch depth
- Backup laser much shorter focal length, original laser stays coherent longer

The factors we want to control:

- Spot Size
- Etch Depth
- DPI

Original Laser Initial Results Backup Laser Initial Results

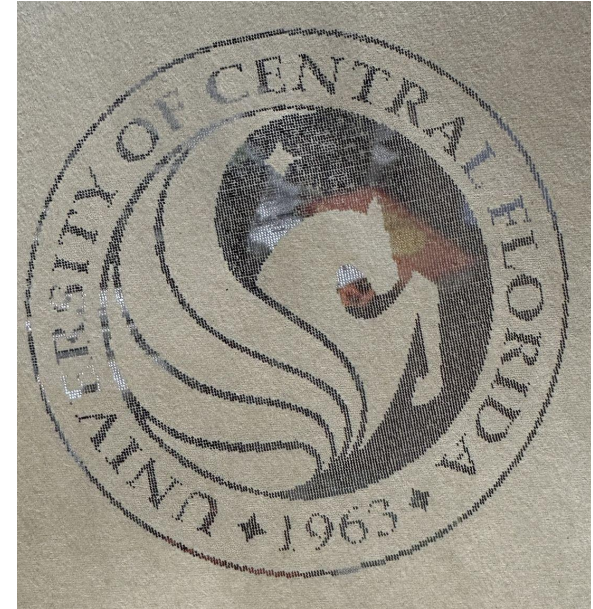
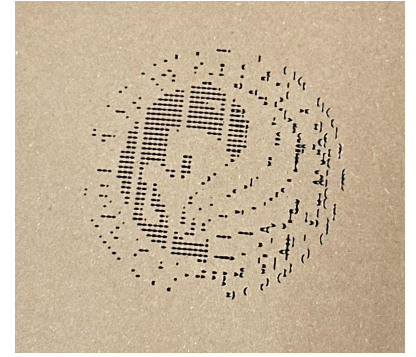
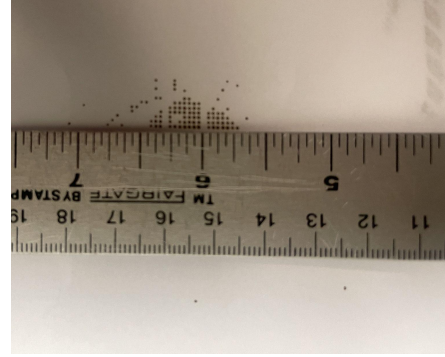



Laser Print Frame

- Before starting a print
 - Option to view the print frame
- The purpose of this system
 - Tell the user where the edge of the print is with a safe laser

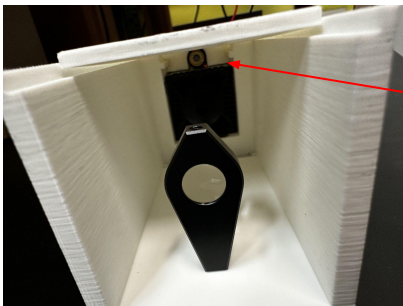

650 nm laser pointer

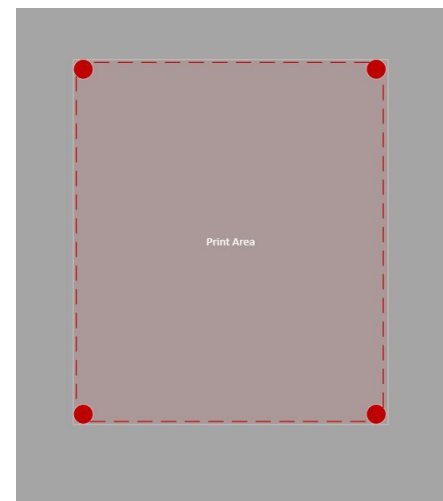
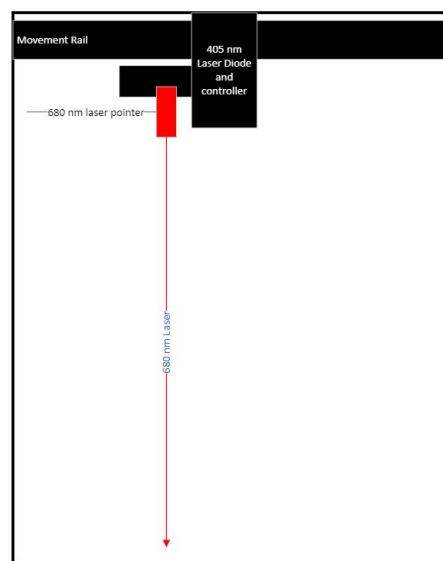



Distance Sensing and Fire Detection

- These are two secondary optical components
- They will both make use of the same electrical circuits
- Same fundamental concept
- Compare voltages to adjust the resolution

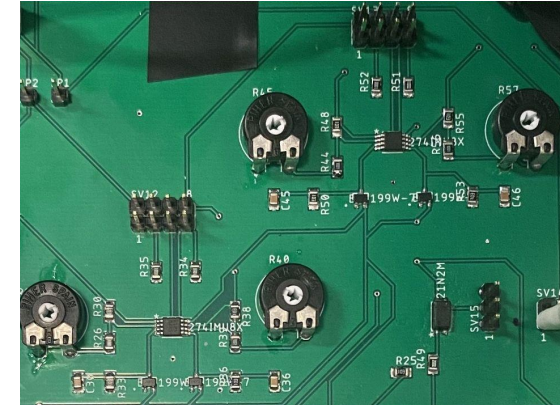

- Components used in working prototypes:
 - 5 mm IR Emitter
 - 5 mm IR Receiver
 - Makes use of a comparator circuit
 - TSV912IST Op Amp

Distance Sensing

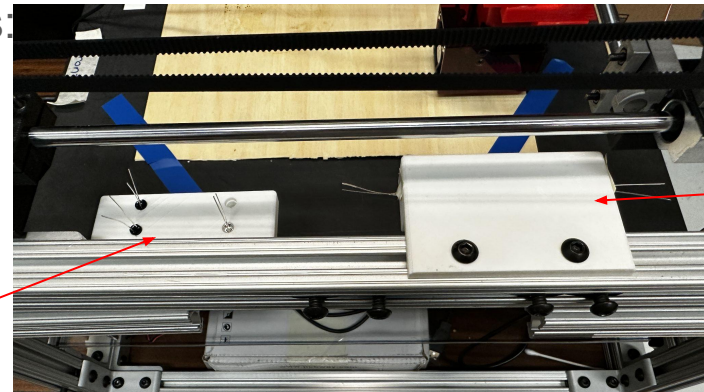

Fire Detection



Distance Sensor

- Mounted on the top the top side of the system
- Works to measure distance
- Makes use of a reflective flat metal material
 - Require user to place a reflective material on top of the print material
 - The reflective material height is accounted for in the measurement
- The value is read by the microcontroller and averaged by the two photodiodes
- Uses one IR LED due to two being excessive

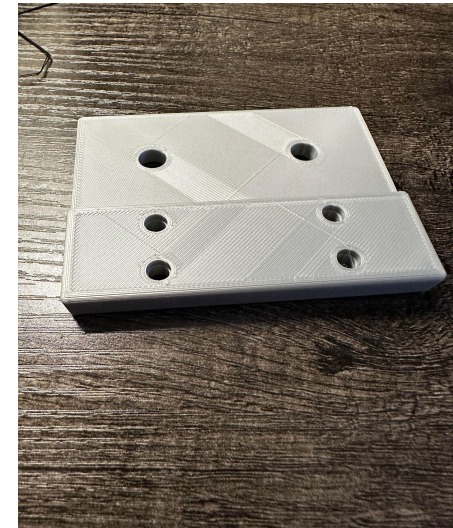
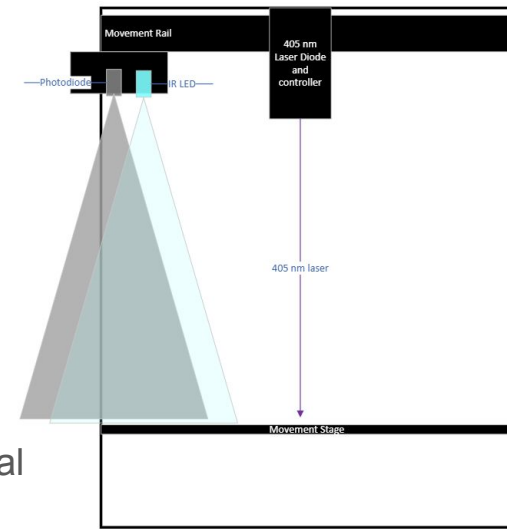



Fire Detection System

- Same circuit as the distance sensor
- LED and Photodiode will not be able to sense the other
- When smoke/fumes present light is scattered
- Photodiode to detects intensity
- Fire Detection System is tripped
- Causes system to stop lasing
- Waits to see if its just fumes or actual smoke

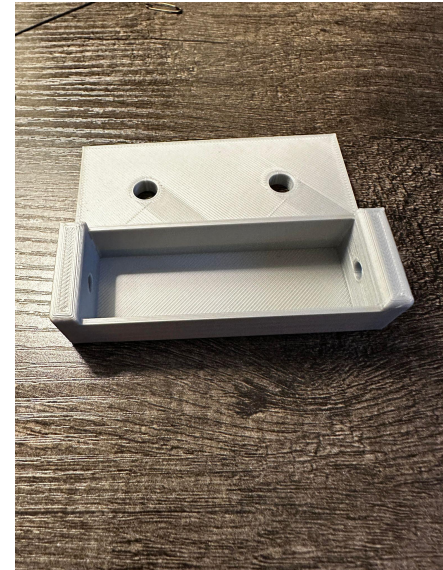
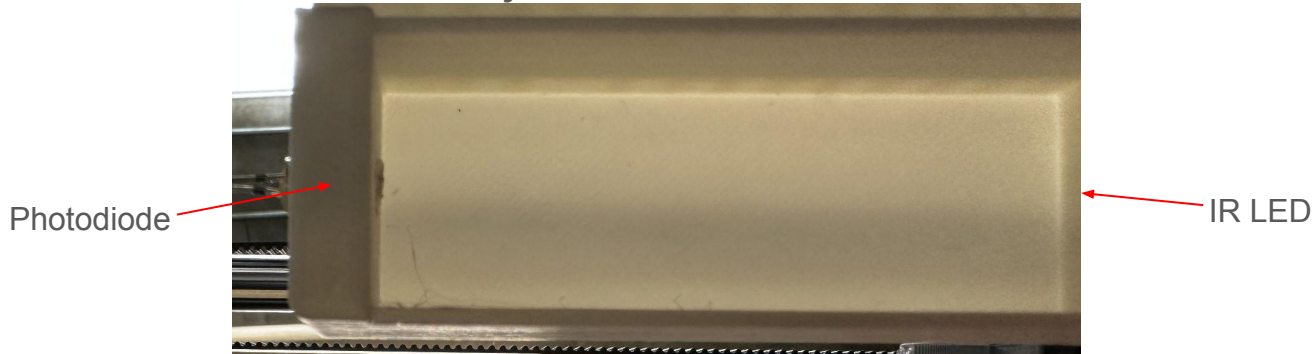
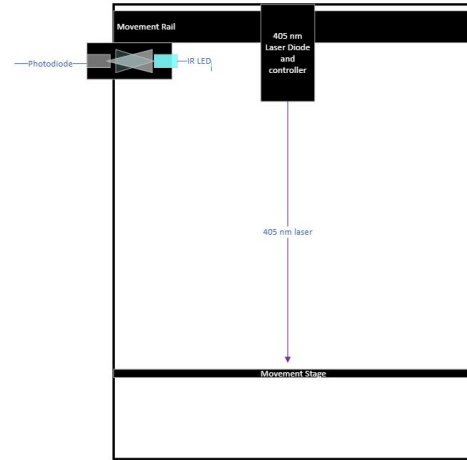



Budget

	Material	Unit Cost	Quantity	Total Cost
Optical	405nm Laser	\$50	1	\$50
Optical	Backup Laser	\$100	1	\$100
Optical	Laser Mount	\$20	1	\$20
Optical	LEDs	\$15	1	\$15
Optical	Photodetectors	\$10	1	\$10
Optical	Lenses	\$40	2	\$80
Optical	650nm Laser	\$10	1	\$10
Optical	Warning Labels	\$10	2	\$20
Comp.	Microcontroller / microprocessor	\$30	1	\$30

Total Cost Estimate:

\$682

Electric.	Stepper Motors	\$15	3	\$45
Electric.	AC Adapter Power Supply	\$20	1	\$20
Electric.	Motor Controllers	\$6	3	\$18
Electric.	Custom PCB	\$11	4	\$44
Electric.	Misc. PCB Components	\$40	N/A	\$40
Electric.	DC Fans	\$5	3	\$15

Mech.	3D Printer Filament	\$20	1	\$20
Mech.	Various Paper Types	\$20	1	\$20
Mech.	Plastic	\$50	1	\$50
Mech.	Misc.	\$75	1	\$75



Work Distribution

	Laser	Distance Sensor	Fire Detection	Firmware	Power	PCBs	Mechanical Gantry	Frame
Sean	++	+++	+++				++	+++
Ethan	+++	+	++				+	
Ifran		++	++		+++	+++		
Franklin				+++	+	+	+++	++

Conclusion and Future Improvements

Conclusion

- Project meets all Basic requirements and functions
- We are capable of printing high resolution images
- Final design is higher quality than the initial design

Future Improvements

- Replace Laser system with the originally spec'd hardware.
- Add Quality of Life to GUI
- Make distance sensing more accurate
- Continue pursuing iterative improvements to coding
- Quieter Movement
- Optimize Printer paper

